

Detail X

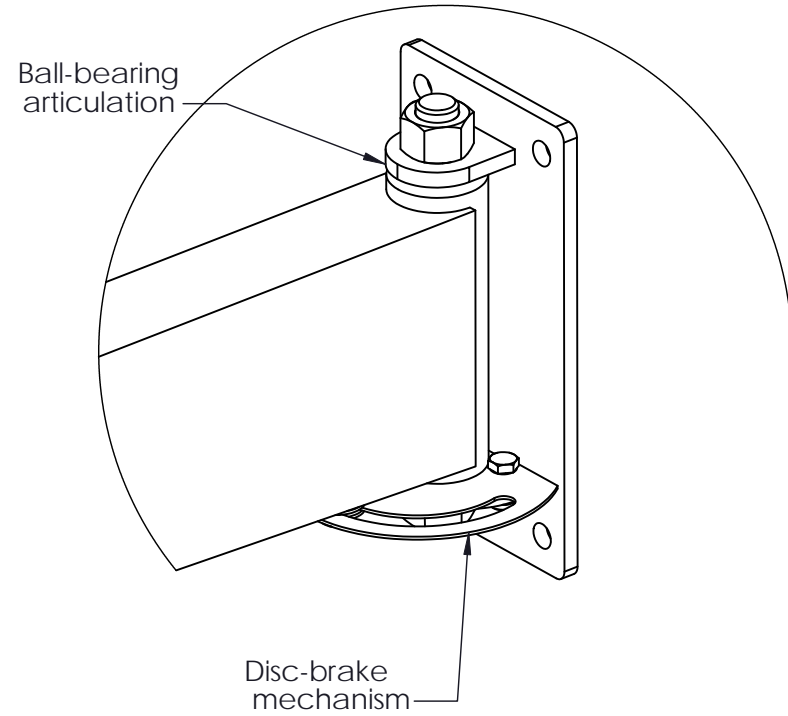

Wall Mounting Flange

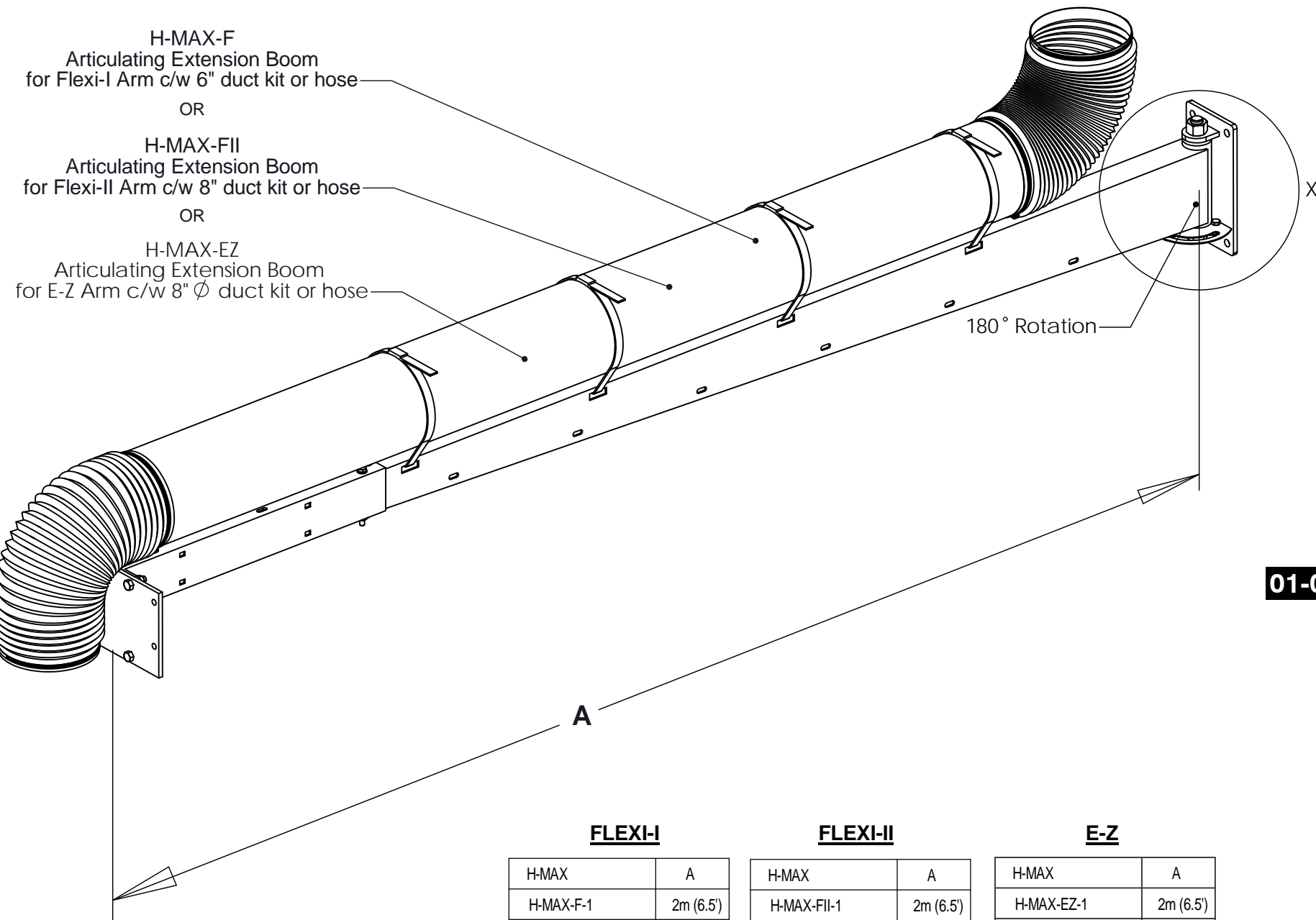
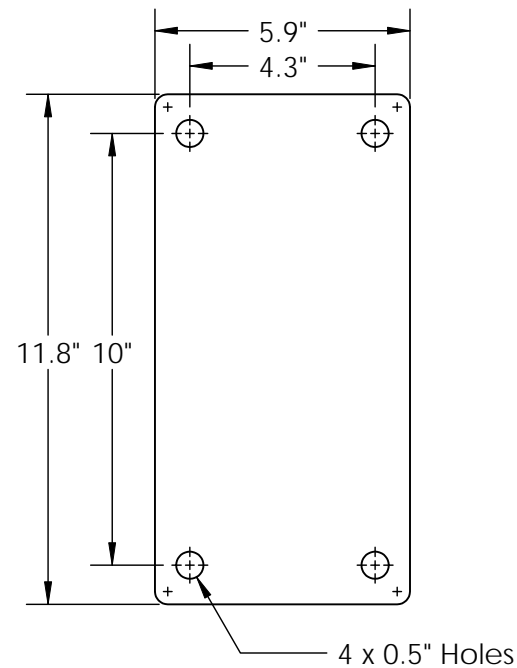

01-09

FLEXI-I

H-MAX	A
H-MAX-F-1	2m (6.5')
H-MAX-F-2	3m (10')
H-MAX-F-3	4m (13')
H-MAX-F-4	5m (16.5')
H-MAX-F-1/D	2m (6.5')
H-MAX-F-2/D	3m (10')
H-MAX-F-3/D	4m (13')
H-MAX-F-4/D	5m (16.5')

FLEXI-II

H-MAX	A
H-MAX-FII-1	2m (6.5')
H-MAX-FII-2	3m (10')
H-MAX-FII-3	4m (13')
H-MAX-FII-4	4m (16.5')
H-MAX-FII-1/D	2m (6.5')
H-MAX-FII-2/D	3m (10')
H-MAX-FII-3/D	4m (13')

E-Z

H-MAX	A
H-MAX-EZ-1	2m (6.5')
H-MAX-EZ-2	3m (10')
H-MAX-EZ-3	4m (13')
H-MAX-EZ-1/D	2m (7')
H-MAX-EZ-2/D	3m (10')
H-MAX-EZ-3/D	4m (13')

CUSTOMER:
CUSTOMER P.O.:
PROJECT:
ENGINEER:
SALES REP.:
IDENTIFICATION / TAGGING:

> www.lev-co.com • 1.888.862.5356



The device depicted and described hereon embodies proprietary information owned by the manufacturer. All design, manufacturing, reproduction, sales and patent rights regarding this device or drawing reserved except where explicit right is guaranteed in writing. We reserve the right to make design changes.

Drawn by: DAN
Date: 5/27/2008
Scale: NTS
Weight: N/A

01-09 H-MAX Extension Booms for FLEXI-I, FLEXI-II and E-Z Arms
Specification Drawing

Drawing No.: -
Material: -
File Name: (01-09) H-MAX Extension Boom - S
Sheet: 1/2

MODELS & OPTIONS:

H-MAX WITH E-Z ARM

H-MAX WITH FLEXI ARM

Part # Description

H-Max Articulating Extension Boom for Flexi-I

- H-MAX-F-1 2m (6.5') H-MAX Boom Kit for FLEXI-I Extraction Arms c/w hose.
- H-MAX-F-1/D 2m (6.5') H-MAX Boom Kit for FLEXI-I Extraction Arms c/w duct kit.
- H-MAX-F-2 3m (10') H-MAX Boom Kit for FLEXI-I Extraction Arms c/w hose.
- H-MAX-F-2/D 3m (10') H-MAX Boom Kit for FLEXI-I Extraction Arms c/w duct kit.
- H-MAX-F-3 4m (13') H-MAX Boom Kit for FLEXI-I Extraction Arms c/w hose.
- H-MAX-F-3/D 4m (13') H-MAX Boom Kit for FLEXI-I Extraction Arms c/w duct kit.
- H-MAX-F-4 5m (16.5') H-MAX Boom Kit for FLEXI-I Extraction Arms c/w hose.
- H-MAX-F-4/D 5m (16.5') H-MAX Boom Kit for FLEXI-I Extraction Arms c/w duct kit.

H-Max Articulating Extension Boom for Flexi-II

- H-MAX-FII-1 2m (6.5') H-MAX Boom Kit for FLEXI-II Extraction Arms c/w hose.
- H-MAX-FII-1/D 2m (6.5') H-MAX Boom Kit for FLEXI-II Extraction Arms c/w duct kit.
- H-MAX-FII-2 3m (10') H-MAX Boom Kit for FLEXI-II Extraction Arms c/w hose.
- H-MAX-FII-2/D 3m (10') H-MAX Boom Kit for FLEXI-II Extraction Arms c/w duct kit.
- H-MAX-FII-3 4m (13') H-MAX Boom Kit for FLEXI-II Extraction Arms c/w hose.
- H-MAX-FII-3/D 4m (13') H-MAX Boom Kit for FLEXI-II Extraction Arms c/w duct kit.
- H-MAX-FII-4 5m (16.5') H-MAX Boom Kit for Flexi-II Extraction Arms c/w Hose

H-Max Articulating Extension Boom for E-Z ARM

- H-MAX-EZ-1 2m (6.5') H-MAX Boom Kit for E-Z Arms c/w hose.
- H-MAX-EZ-1/D 2m (6.5') H-MAX Boom Kit for E-Z Arms c/w duct kit.
- H-MAX-EZ-2 3m (10') H-MAX Boom Kit for E-Z Arms c/w hose.
- H-MAX-EZ-2/D 3m (10') H-MAX Boom Kit for E-Z Arms c/w duct kit.
- H-MAX-EZ-3 4m (13') H-MAX Boom Kit for E-Z Arms c/w hose.
- H-MAX-EZ-3/D 4m (13') H-MAX Boom Kit for E-Z Arms c/w duct kit.

Installation Accessories

- H-Max-F-RED 6.3" x6" Short reducer powder coated black
- P-030 160mm (6") turning joint (swivel)
- P-031 200mm (8") dia. turning joint (swivel)

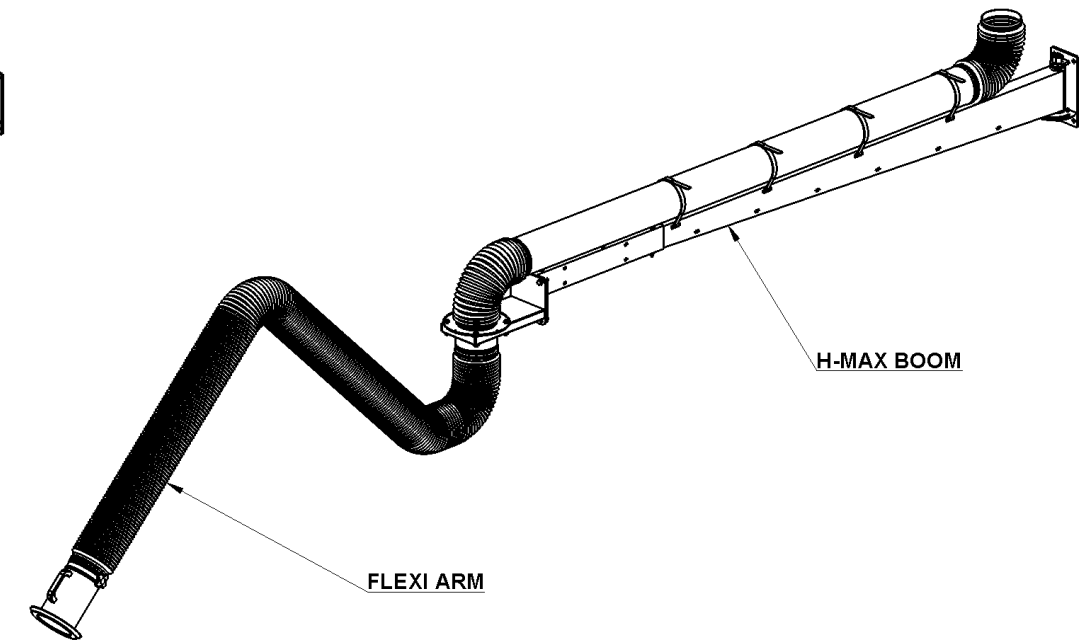
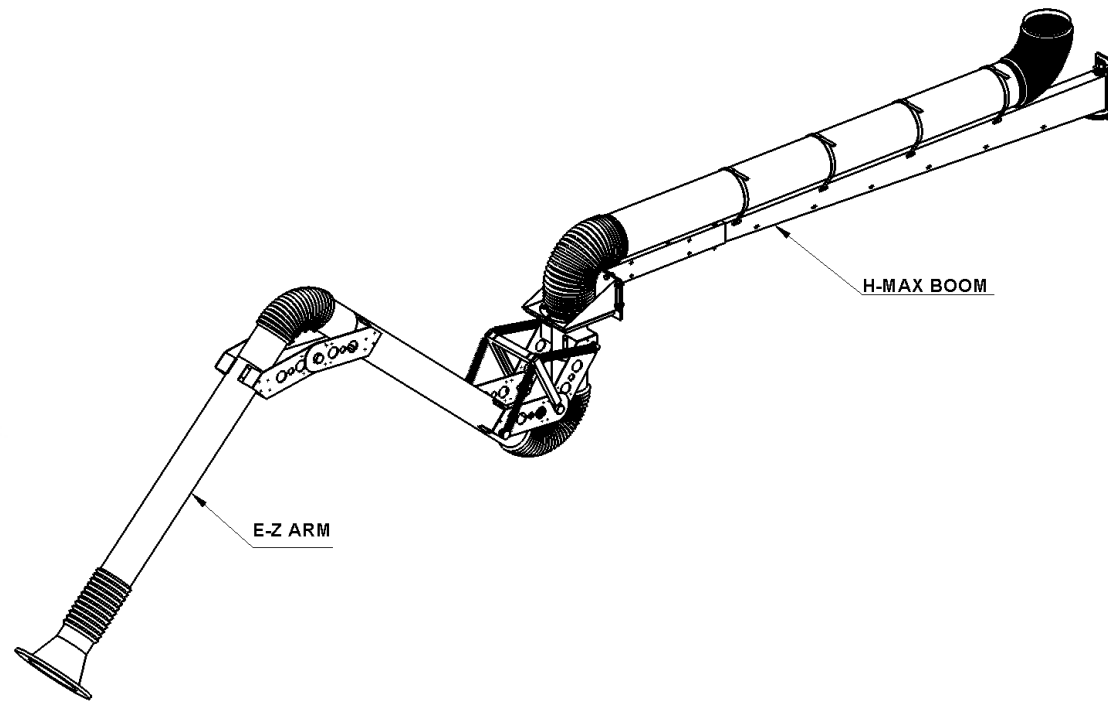

H-MAX WITH HOSE REEL

H-MAX PRECEDED BY HERCULIAN BOOM

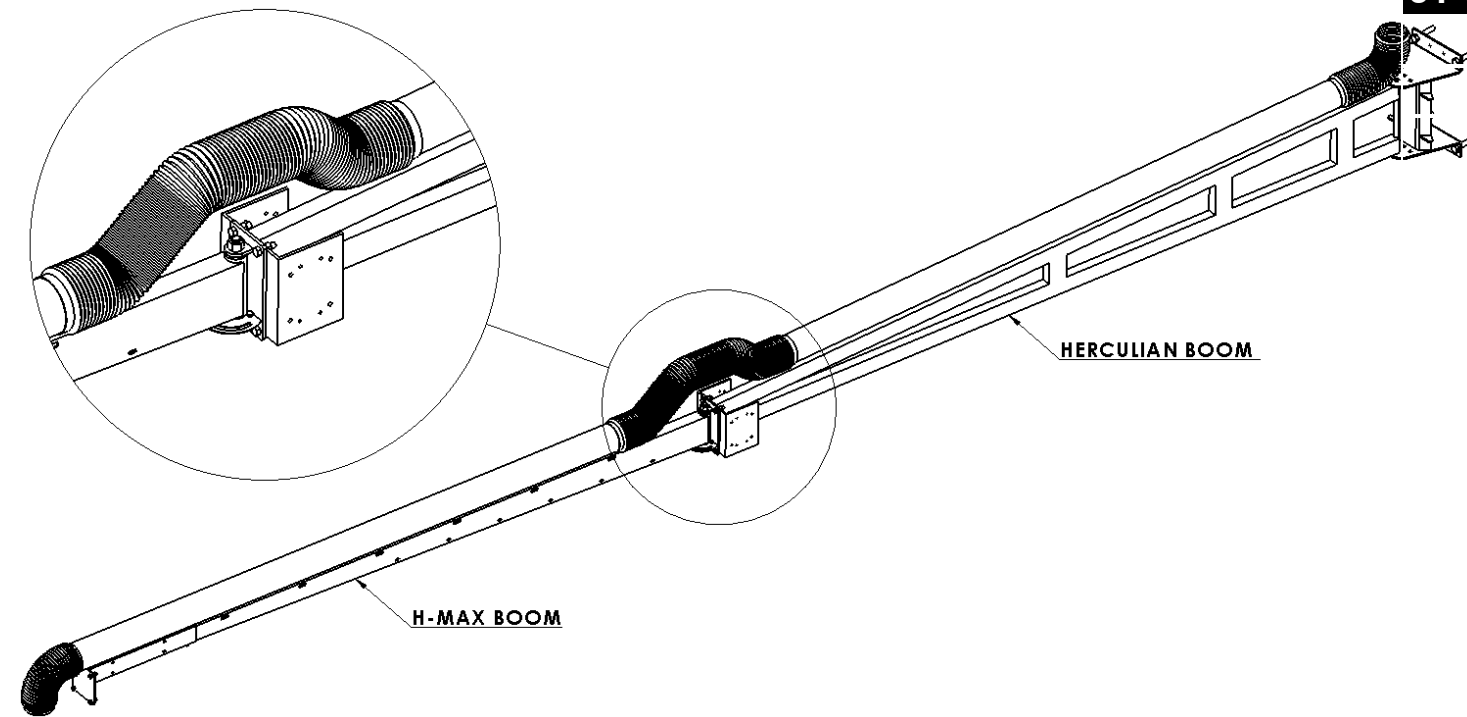
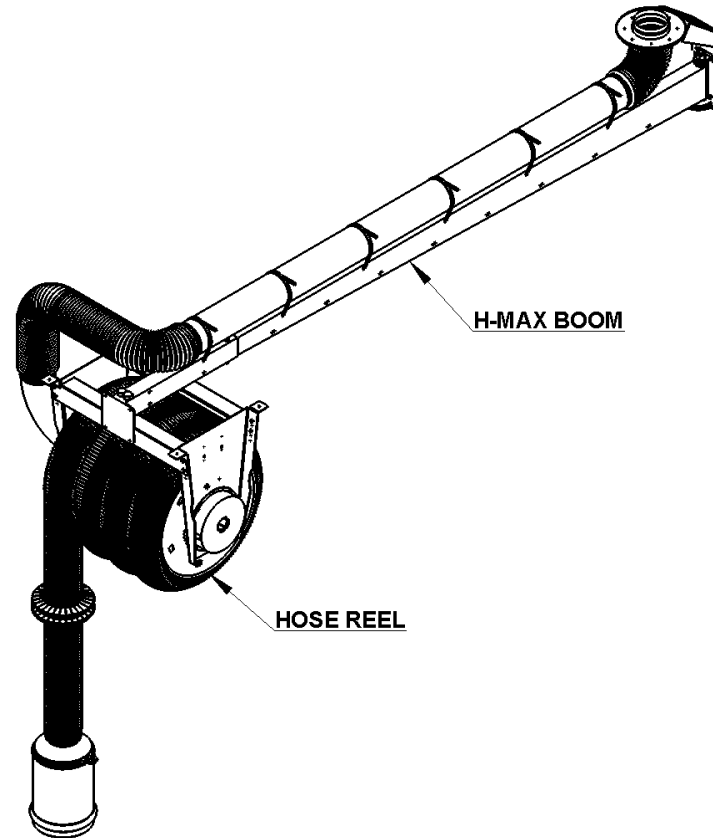

01-09

CUSTOMER:	
CUSTOMER P.O.:	
PROJECT:	
ENGINEER:	
SALES REP.:	
IDENTIFICATION / TAGGING:	

> www.lev-co.com • 1.888.862.5356



The device depicted and described hereon embodies proprietary information owned by the manufacturer. All design, manufacturing, reproduction, sales and patent rights regarding this device or drawing reserved except where explicit right is guaranteed in writing. We reserve the right to make design changes.

Drawn by:	DAN
Date:	5/27/2008
Scale:	NTS
Weight:	N/A

01-09 H-MAX Extension Booms for FLEXI-I, FLEXI-II and E-Z Arms
Specification Drawing

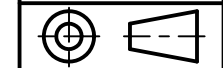

Drawing No.:	-	File Name:	(01-09) H-MAX Extension Boom - S
Material:	-	Sheet:	2/2