

## SPECIFICATIONS:

### CONSTRUCTION:

12/14/16 Gauge steel cabinet finished with Powder-Coat Finish. Includes a 10 gallon external dust drawer, removable end cap for easy access to filters, removable panel for easy access to direct drive motor/blower, 25' 12 Ga. power cord, and on-off switch. Motor wired to junction box outside of unit for 3 phase option. Acoustical lining standard in blower compartment. Vibra-Pulse cleaning standard.

### WEIGHT:

260 lbs.

### AIRFLOW:

1000 CFM with std. 1.5 HP motor  
1200 CFM with opt. 3 HP motor

### NOISE:

77 dBA - 1.5 HP  
79 dBA - 3 HP

### ELECTRICAL:

- 1.5 HP 115/220/1/60, 15/7.9-7.5 amps, std
- 1.5 HP 230/460/3/60, 4.9-4.6/2.3 amps, opt.
- 3 HP 208-230/460/3/60, 8.4-8.0/4.0 amps, opt.

### FIRE SUPPRESSION:

Equipment provided by others.

### SPECIAL NOTES:

Compressed air filter provided by others.

### MAIN FILTERS:

- (2) CLEAN-2 Filter cartridge, 16"Dx12", Std.
- (2) Cartridge, FIBERDUST, Opt.
- (2) Cartridge, Spark Resistant, Opt.
- (2) Cartridge, Spunbond - H0, Opt.
- (2) Cartridge, CleanPlus double treated fire retardant, Opt.

### HEPA OPTIONS:

- (1) External HEPA filter, 99.97%

### AD OPTION:

- (1) External adsorber, 25 lb. capacity

### OTHER OPTIONS:

- Pressure gauge kit indicates filter changes
- Hopper option
- Auto Clean, (w/Hopper opt.)
- Regulator
- 14 Ft. E-Z Arm
- Silencer (Adds 3" to depth of unit)

\* AFS FILTER EFFICIENCIES BASED ON ASHRAE 52-76 TEST METHOD

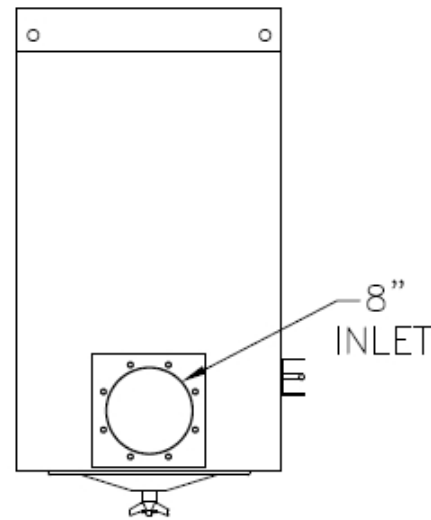

TOP VIEW

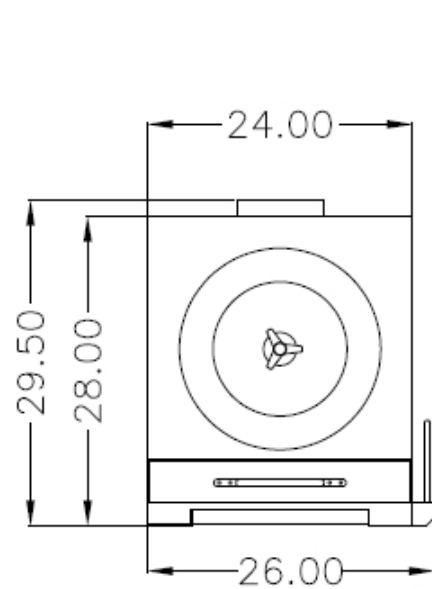

BACK VIEW

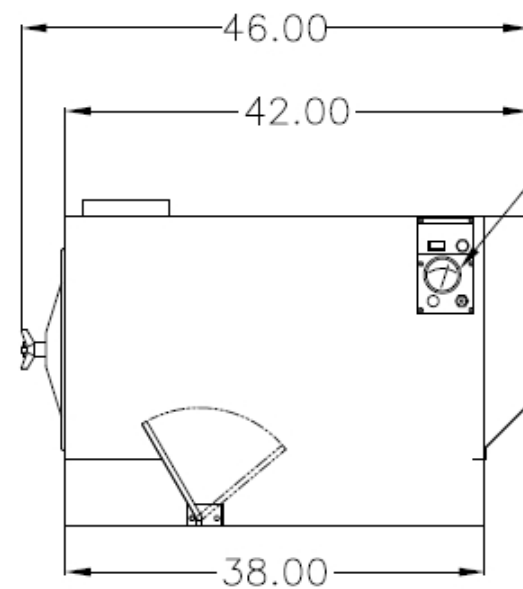

SIDE VIEW

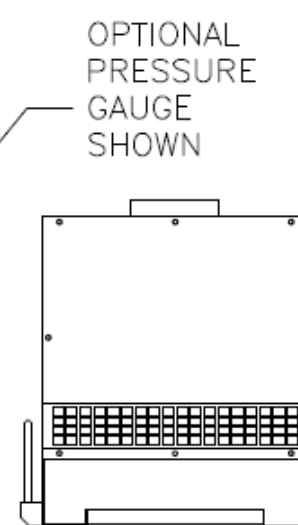

FRONT VIEW

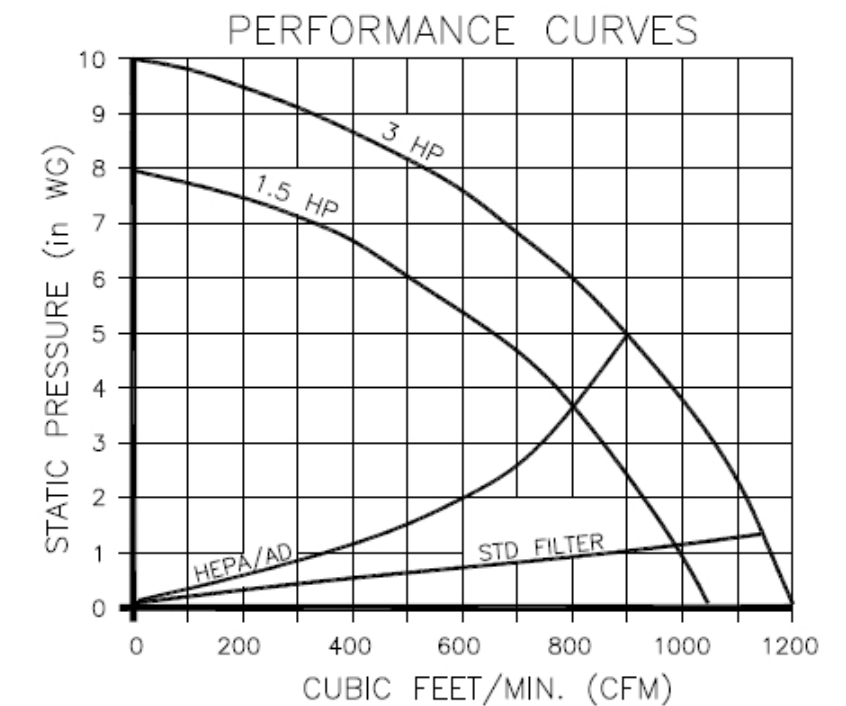
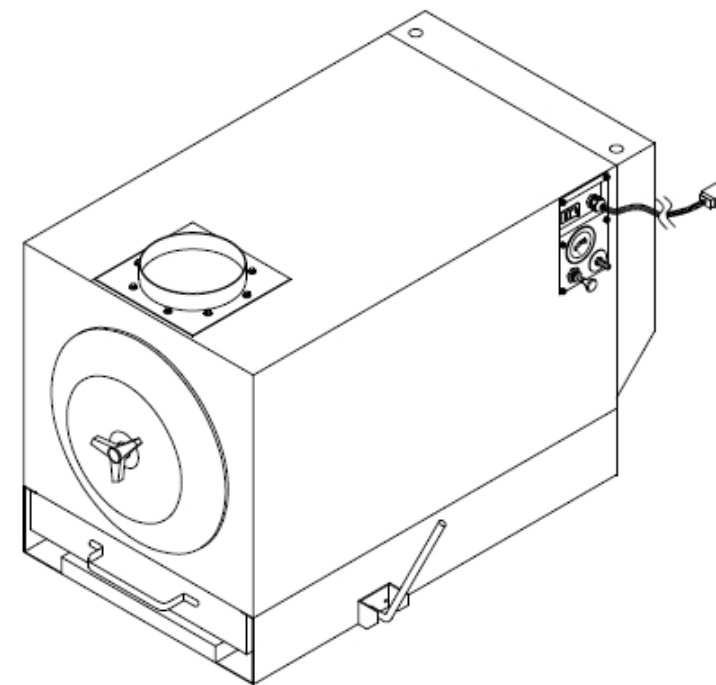

03-03

CUSTOMER:	
CUSTOMER P.O.:	
PROJECT:	
ENGINEER:	
SALES REP.:	
IDENTIFICATION / TAGGING:	

> [www.lev-co.com](http://www.lev-co.com) • 1.888.862.5356



The device depicted and described hereon embodies proprietary information owned by the manufacturer. All design, manufacturing, reproduction, sales and patent rights regarding this device or drawing reserved except where explicit right is guaranteed in writing. We reserve the right to make design changes.

Drawn by:	Janos B
Date:	5/1/2008
Scale:	NTS
Weight:	N/A

<b>03-03 DCH-2</b>	
<b>c/w External Tray or Hopper</b>	
<b>Specification Drawing</b>	
Drawing No.:	File Name: (03-03) DCH-2 - SD
Material:	Product manufactured by: <b>Airflow SYSTEMS INC.</b>
Sheet: 1/2	

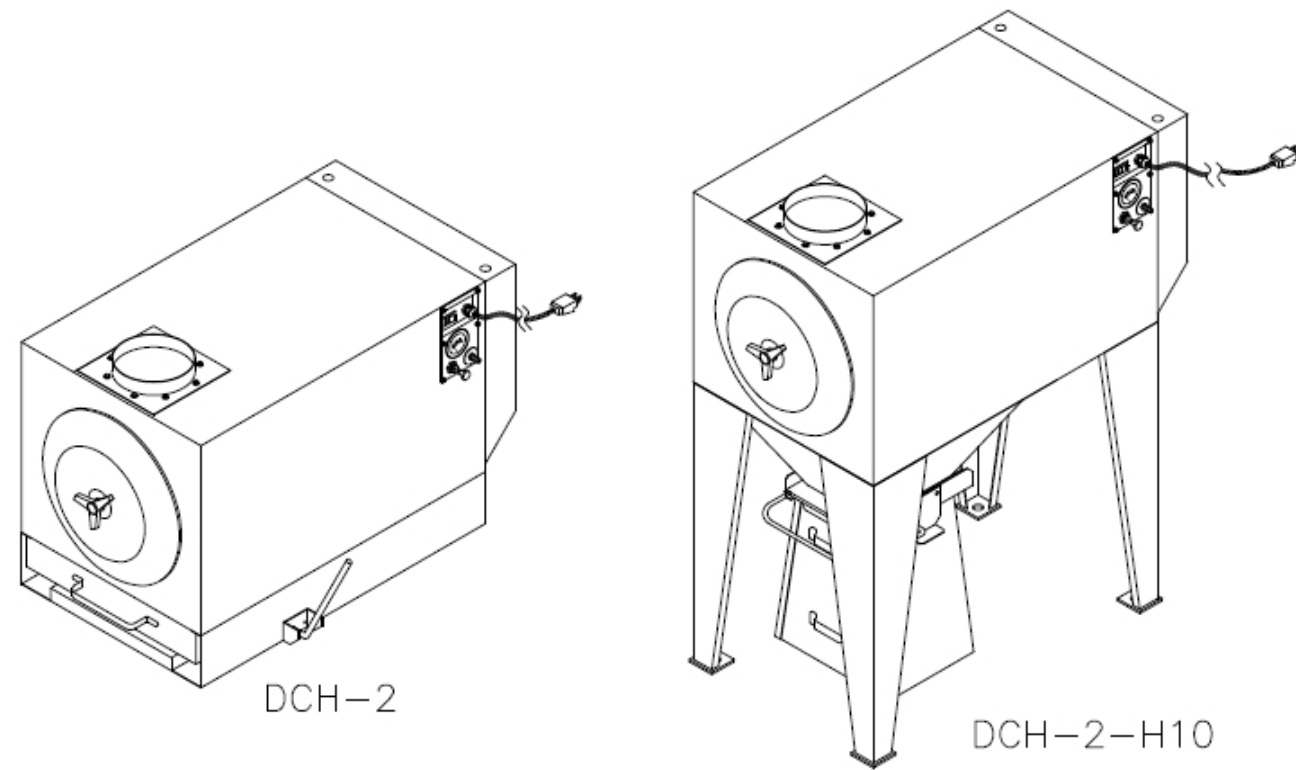

DCH-2

DCH-2-H10

HOPPER OPTION AND  
EXTERNAL HEPA/AD  
OPTION

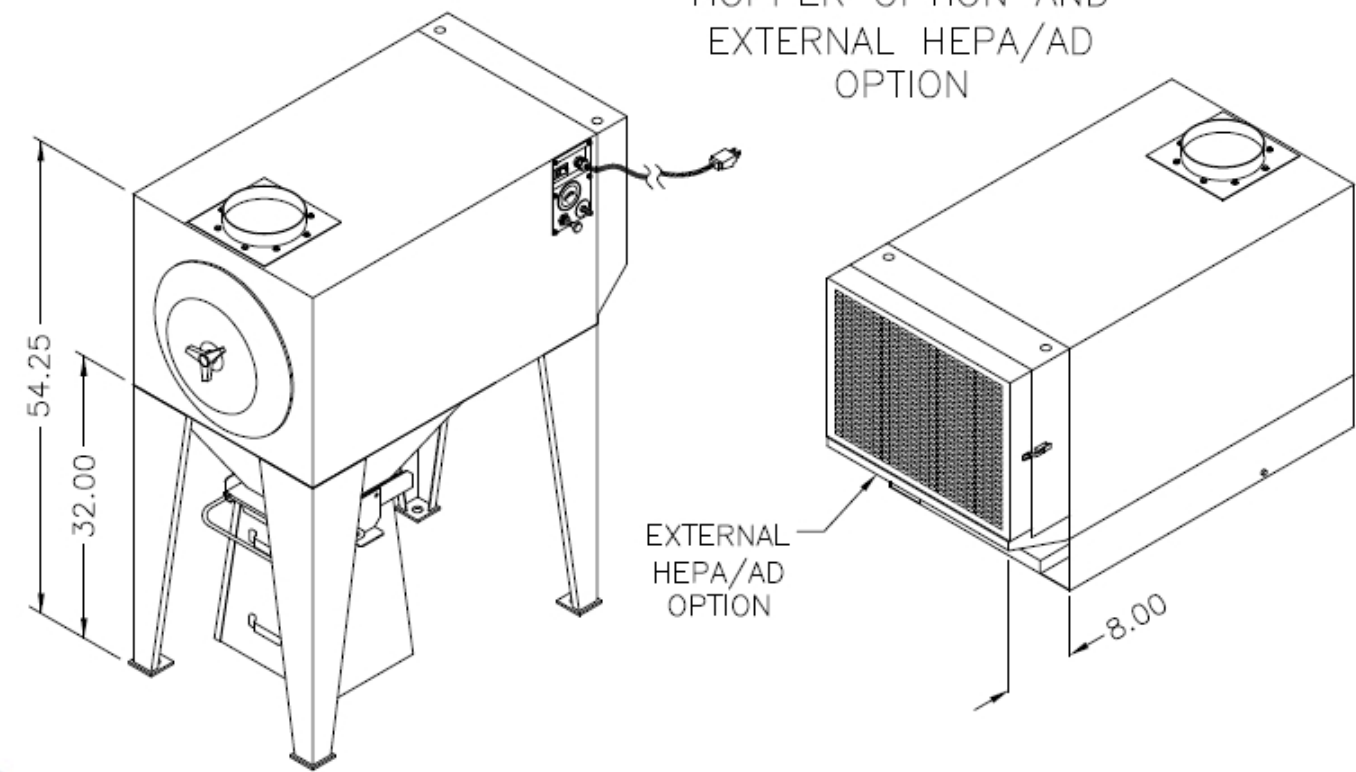

EXTERNAL  
HEPA/AD  
OPTION

**MODELS & OPTIONS:**

- Main System / Part**
- DCH-2 Cartridge collector w/2 Clean 2® cartridge filters (150 ft2 media each) manual Vibra-Pulse®. 1.5HP
  - DCH-2-H10 Cartridge collector w/10 gallon Hopper (w/ stand & dust can) 2 Clean 2® cartridge filters (150 ft2 media each)

- Fan / Motor Upgrades or Options (when ordering main unit)**
- DCH-2-1PHASE-D 1.5 Hp, 1 phase, Class 1, Div. 2, Group D motor/blower for the DCH-2
  - DCH-2-3 PHASE 1.5 Hp, TEFC motor 208-230-460/575/3/60 Hz, Standard Blower Option for Standard DCH-2 Unit
  - DCH-2-3HP 3 Hp TEFC motor,208-230/460/575/3/60 Hz, High Flow Option for Standard DCH-2 Unit
  - DCH-2-3HP-1PHASE 3 Hp TEFC motor,230/1/60 Hz, High Flow Option for Standard DCH-2 Unit

- Filter Options (when ordering main unit)**
- DCH-2-AD Internal AD Option for Standard DCH-2 Unit
  - DCH-2-EXAD External Adsorber Module Option for Standard DCH-2 Unit
  - DCH-2-EXDOP External 95% DOP Filter Option for Standard DCH-2 Unit
  - DCH-2-EXHE External 99.97% HEPA Filter Option for Standard DCH-2 Unit
  - DCH-2-FD Fiber dust Filters Option for Standard DCH-2 Unit
  - DCH-2-UCP ULTRACLEAN-PLUS Cartridge Filters Option for Standard DCH-2 Unit

- Preventative Maintenance Pressure Gauges, etc. (when ordering main unit)**
- DCH-2-PG-10 0-10" magna-helic pressure gauge, approximately 5" diameter size. Surface mounted.

- Misc. Options**
- DCH2-EXTVENT Explosion vent
  - DCH-2-CASTERS 8" Fixed-front, 5" Swivel-rear Casters Option for Standard DCH-2 Unit ONLY.
  - DCH-2-HYD-045 Hydro-filter designed to help eliminate sparks. C/w 45 gallon drum, easy to remove lid, water level gauge, and
  - OM-019/160 Standing Flange for mounting Flexi-I Arms on DCH/PCH units
  - OM-019/200 Standing Flange for mounting Flexi II arms on DCH/PCH units

- Sound Attenuation**
- DCH-2-S-EXT External Silencer Option for Standard DCH-2 Unit

- Fan, Light & Other**
- DCH-2-AP-1 Off line Auto Pulse, 1 Phase Option for Standard DCH-2 Unit
  - DCH-2-AP-3 Off line Auto Pulse, 3 Phase Option for Standard DCH-2 Unit

- Retro-Fit Parts**
- 2KT51733 External HEPA Retrofit Kit for PCH-1, PCH-2, DCH-1, DCH-2, DTH-800, DTH-1700
  - 2KT51734 External AD Retrofit Kit for PCH-1, PCH-2, DCH-1, DCH-2, DTH-800, DTH-1700. Charcoal not Included. Please order charcoal separately.
  - 2KT51739 External HEPA & AD Retrofit Kit for PCH-1, PCH-2, DCH-1, DCH-2, DTH-800, DTH-1700. Charcoal not
  - 2KT51768 External Silencer Retrofit Kit for PCH-1, PCH-2, DCH-1, DCH-2, DTH-800, DTH-1700

CUSTOMER:
CUSTOMER P.O.:
PROJECT:
ENGINEER:
SALES REP.:
IDENTIFICATION / TAGGING:

[www.lev-co.com](http://www.lev-co.com) • 1.888.862.5356



The device depicted and described hereon embodies proprietary information owned by the manufacturer. All design, manufacturing, reproduction, sales and patent rights regarding this device or drawing reserved except where explicit right is guaranteed in writing. We reserve the right to make design changes.

Drawn by:	Janos B
Date:	5/1/2008
Scale:	NTS
Weight:	N/A

**03-03 DCH-2**  
**c/w External Tray or Hopper**  
**Specification Drawing**

Drawing No.: -      File Name: (03-03) DCH-2 - SD  
 Material:      Product manufactured by:      Sheet: 2/2