

**REGULAR**

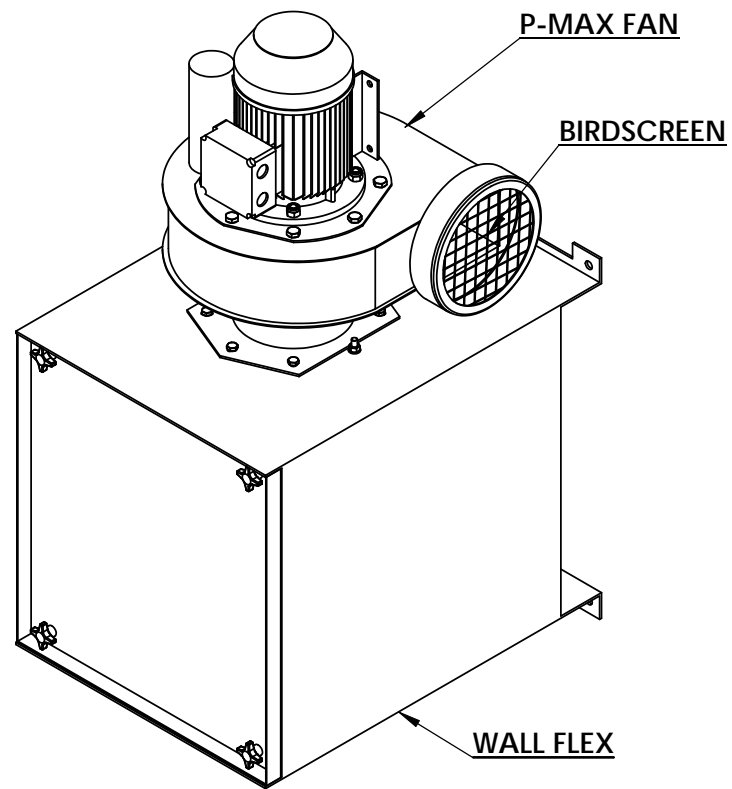

**CONNECTIONS:**

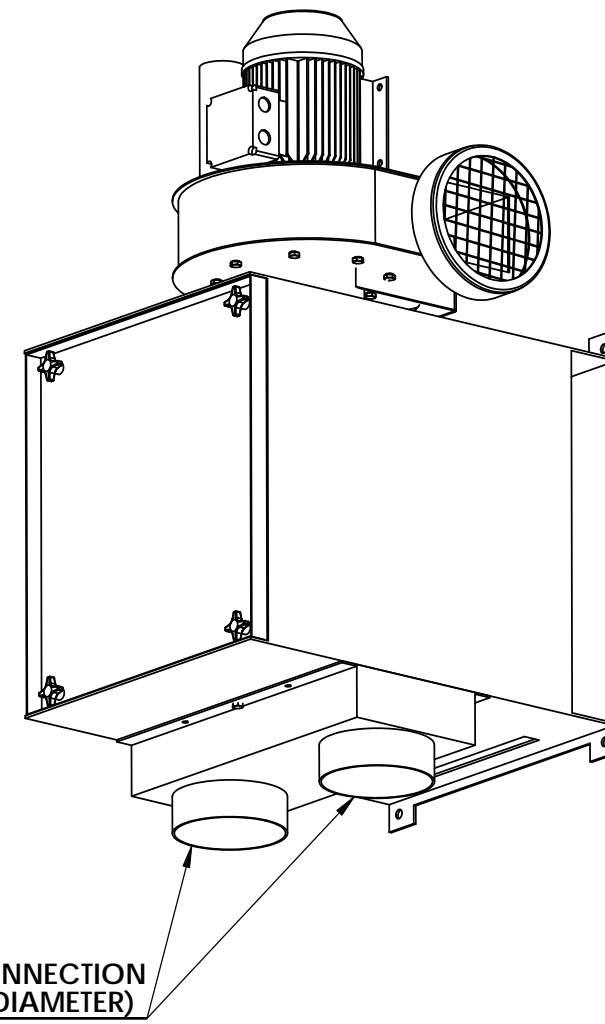
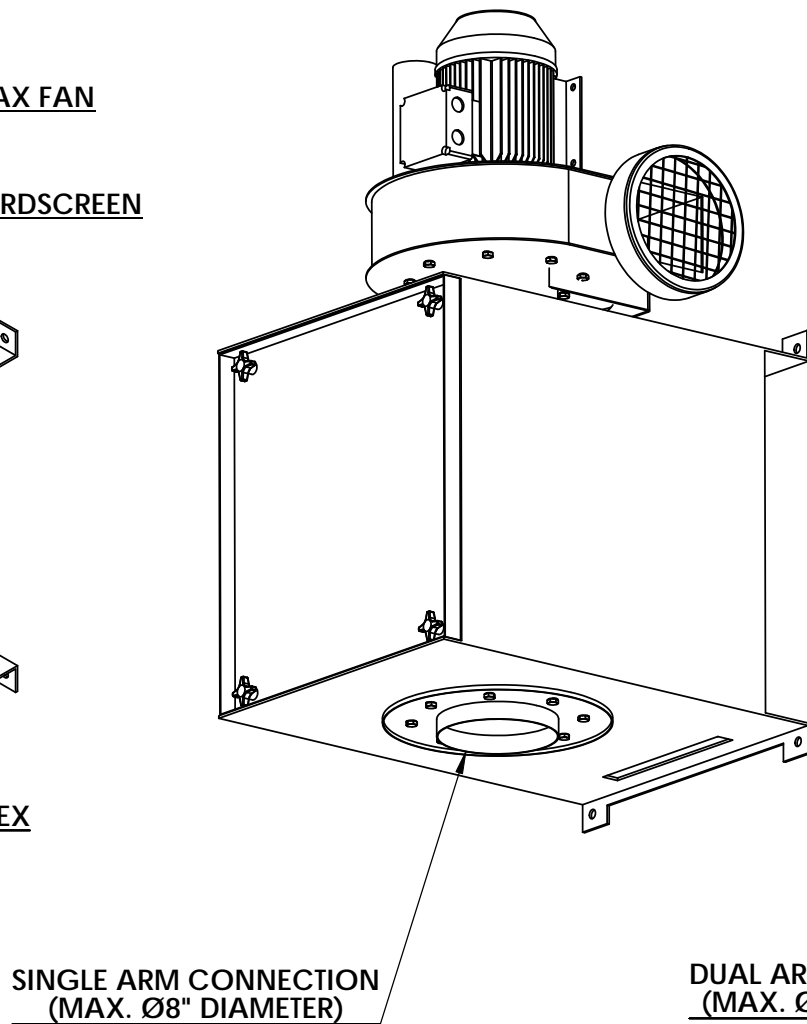

**SELF CLEANING**

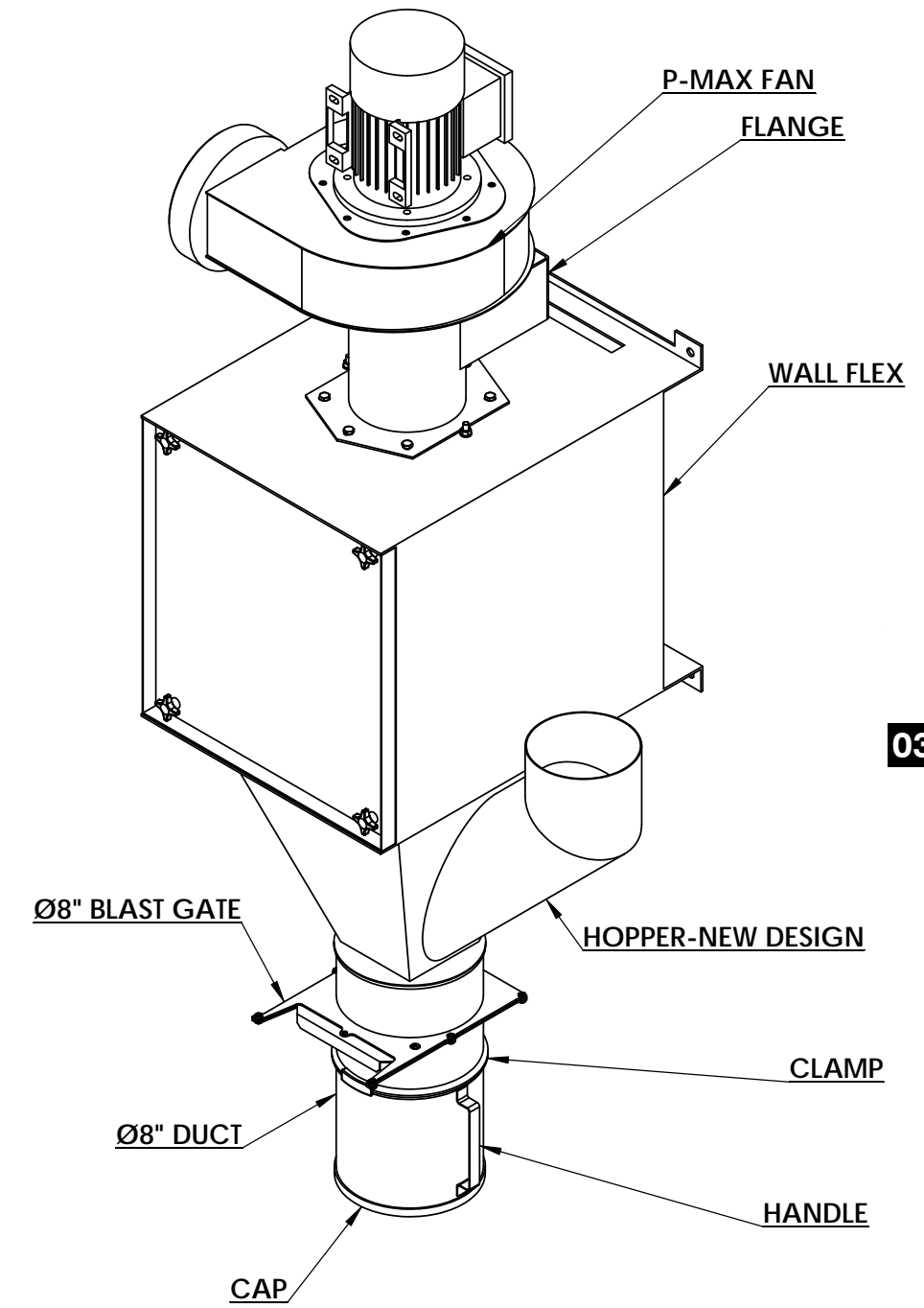

**03-05**

CUSTOMER:
CUSTOMER P.O.:
PROJECT:
ENGINEER:
SALES REP.:
IDENTIFICATION / TAGGING:

[www.lev-co.com](http://www.lev-co.com) • 1.888.862.5356



The device depicted and described hereon embodies proprietary information owned by the manufacturer. All design, manufacturing, reproduction, sales and patent rights regarding this device or drawing reserved except where explicit right is guaranteed in writing. We reserve the right to make design changes.

Drawn by:	Janos B
Date:	3/2/2010
Scale:	NTS
Weight:	N/A

<b>03-05 WALL-FLEX CARTRIDGE DUST COLLECTOR</b>	
Specification Drawing	
Drawing No.:	-
Material:	-
File Name:	(03-05) Wall Flex - SD
Sheet:	1/4

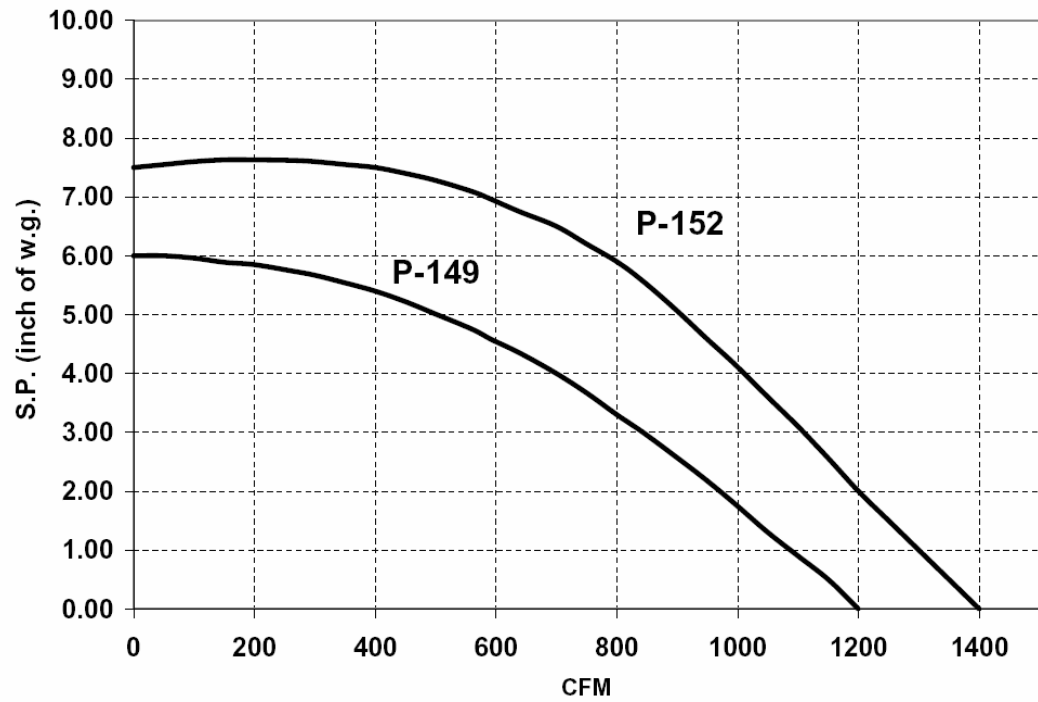
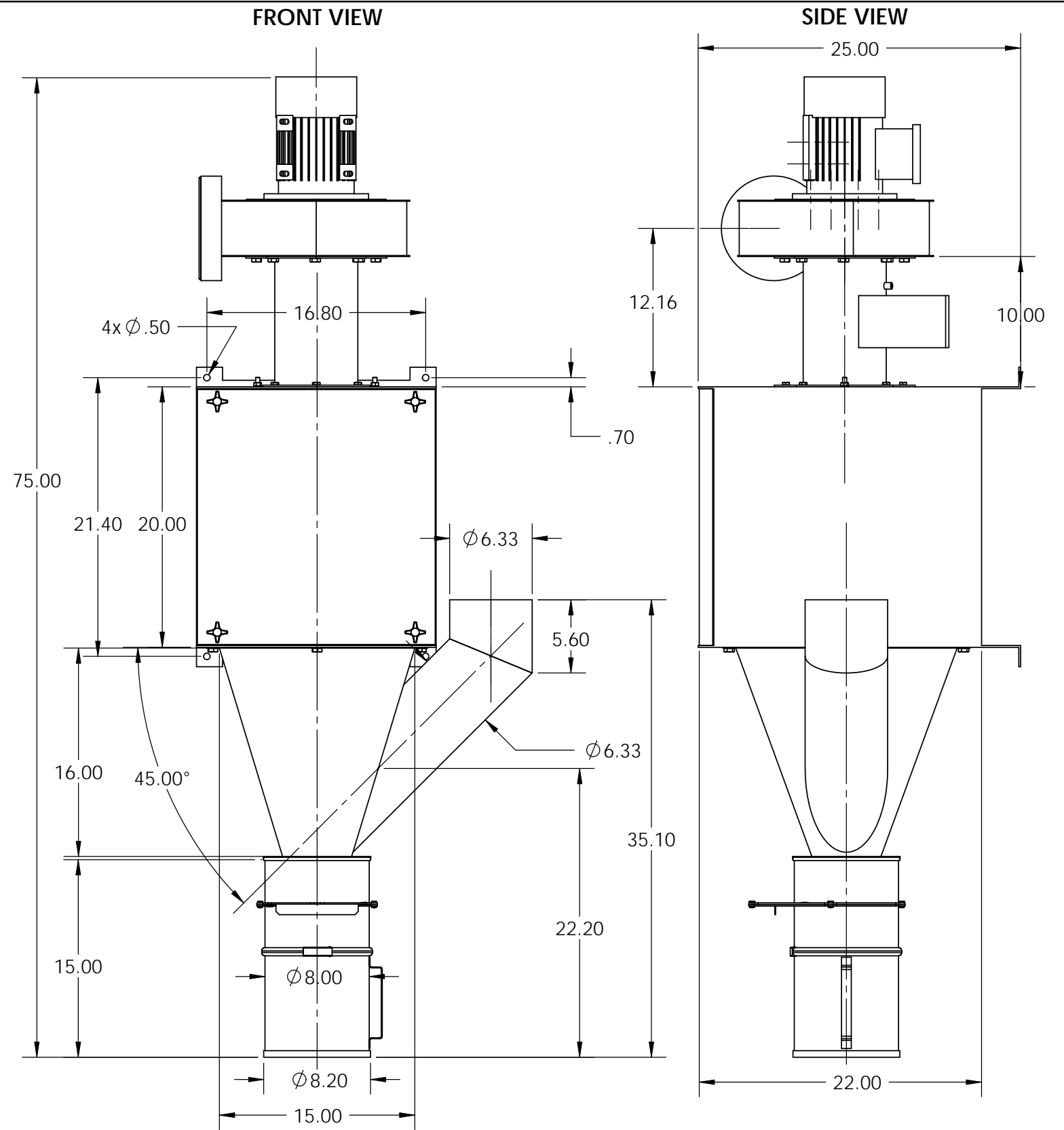
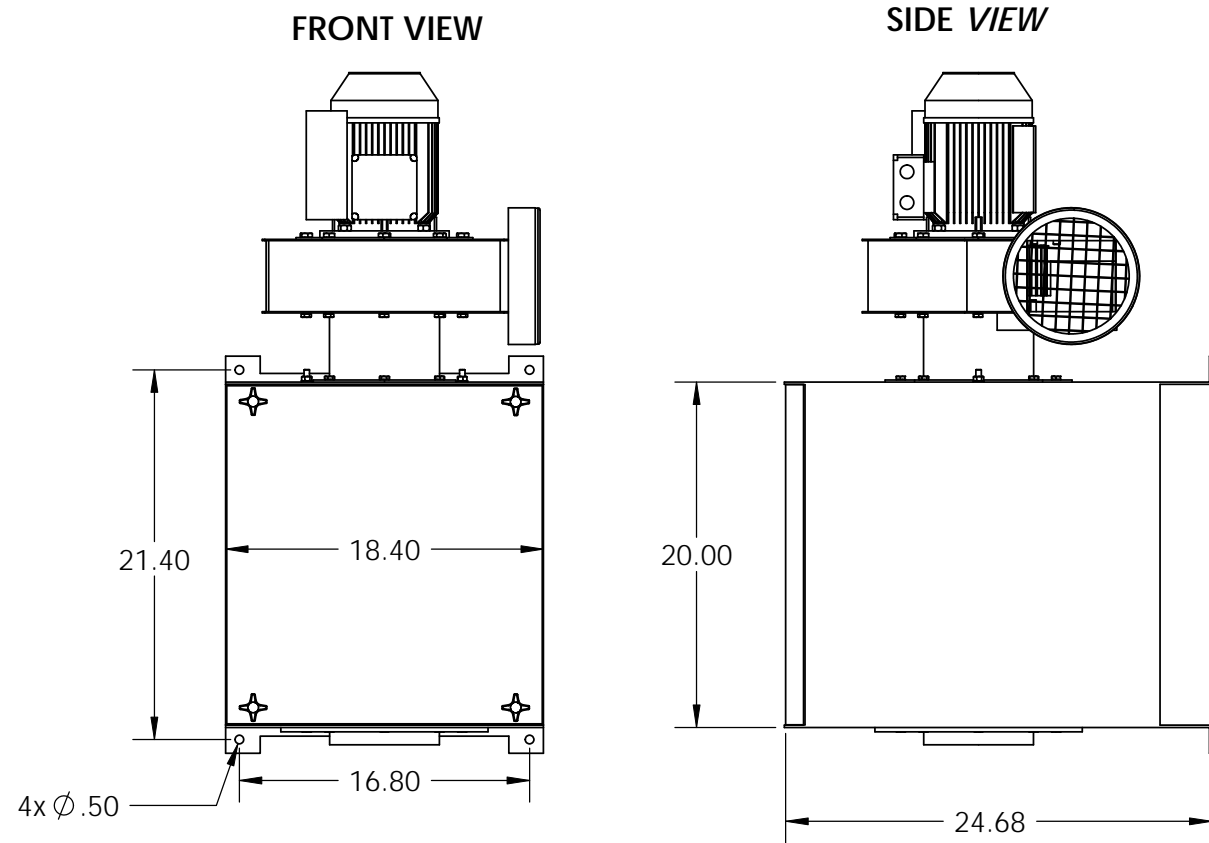

03-05

CUSTOMER:  
 CUSTOMER P.O.:  
 PROJECT:  
 ENGINEER:  
 SALES REP.:  
 IDENTIFICATION / TAGGING:

[www.lev-co.com](http://www.lev-co.com) • 1.888.862.5356



The device depicted and described hereon embodies proprietary information owned by the manufacturer. All design, manufacturing, reproduction, sales and patent rights regarding this device or drawing reserved except where explicit right is guaranteed in writing. We reserve the right to make design changes.

Drawn by: Janos B  
 Date: 3/2/2010  
 Scale: NTS  
 Weight: N/A

**03-05 WALL-FLEX CARTRIDGE DUST COLLECTOR**  
 Specification Drawing

Drawing No.: -  
 Material: -  
 File Name: (03-05) Wall Flex - SD  
 Sheet: 2/4

# MODELS & OPTIONS:

**Main System / Part**  
 [WFHC-1](#) Wall Flex high efficiency filtration system c/w 1.5 HP direct mount P-Max fan 115/1/60 TEFC motor, manual Vibra-Pulse cleaning system, and hopper with 5 gallon dust container.

**Wall-Flex - Standard Configuration**  
 [WF-1](#) Wall Flex high efficiency filtration system c/w 1.5 HP direct mount P-Max fan 115/1/60 TEFC motor.  
 [WF-2](#) Wall Flex high efficiency filtration system c/w 2 HP direct mount P-Max fan 230/3/60 TEFC motor.  
 [WF-3](#) Wall Flex high efficiency filtration system c/w 2 HP direct mount P-Max fan 575/3/60 TEFC motor.  
 [WF-4](#) Wall Flex high efficiency filtration system c/w 2 HP direct mount P-Max fan 230/1/60 TEFC motor.

**Wall-Flex - Odor Removal Configuration**  
 [WF-1/CF](#) Wall Flex high efficiency filtration system c/w 1.5 HP direct mount P-Max fan 115/1/60 TEFC motor and odor removal filter ( CF-45 filter with 40-45 lbs of charcoal included) instead of standard P-160 Filter  
 [WF-2/CF](#) Wall Flex high efficiency filtration system c/w 2 HP direct mount P-Max fan 230/460/3/60 TEFC motor and odor removal filter ( CF-45 filter with 40-45 lbs of charcoal included) instead of standard P-160 Filter  
 [WF-3/CF](#) Wall Flex high efficiency filtration system c/w 2 HP direct mount P-Max fan 575/3/60 TEFC motor and odor removal filter ( CF-45 filter with 40-45 lbs of charcoal included) instead of standard P-160 Filter  
 [WF-4/CF](#) Wall Flex high efficiency filtration system c/w 2 HP direct mount P-Max fan 230/1/60 TEFC motor and odor removal filter ( CF-45 filter with 40-45 lbs of charcoal included) instead of standard P-160 Filter

**Wall-Flex - Filter Gas/Micro - Combo Filter Configuration**  
 [WF-1/P-004-WFC](#) Wall Flex high efficiency filtration system c/w 1.5 HP direct mount P-Max fan 115/1/60 TEFC motor and Filter Gas/Micro-Combo Filter ( P-004-WFC filter with 12-15 lbs of charcoal included) instead of standard P-160 Filter  
 [WF-2/P-004-WFC](#) Wall Flex high efficiency filtration system c/w 2 HP direct mount P-Max fan 230/460/3/60 TEFC motor and Filter Gas/Micro-Combo Filter ( P-004-WFC filter with 12-15 lbs of charcoal included) instead of standard P-160 Filter  
 [WF-3/P-004-WFC](#) Wall Flex high efficiency filtration system c/w 2 HP direct mount P-Max fan 575/3/60 TEFC motor and Filter Gas/Micro-Combo Filter ( P-004-WFC filter with 12-15 lbs of charcoal included) instead of standard P-160 Filter  
 [WF-4/P-004-WFC](#) Wall Flex high efficiency filtration system c/w 2 HP direct mount P-Max fan 230/1/60 TEFC motor and Filter Gas/Micro-Combo Filter ( P-004-WFC filter with 12-15 lbs of charcoal included) instead of standard P-160 Filter

**Ultra Low Noise Fan**  
 [P-152-55dBA](#) ULTRA LOW NOISE P-Max Fan 115v/1/60 1.5hp Fan

**Extraction Arms**  
 [P-006](#) Flexi-I Extraction Arm 160mm (6.5")Ø – 1.5m (05')L.  
 [P-007](#) Flexi-I Extraction Arm 160mm (6.5")Ø – 2m (07')L.  
 [P-008](#) Flexi-I Extraction Arm 160mm (6.5")Ø – 3m (10')L.  
 [P-142](#) Flexi-II Extraction Arm: 200mm (8")Ø – 1.5m (5')L.  
 [P-143](#) Flexi-II Extraction Arm: 200mm (8")Ø – 2m (07')L.  
 [P-144](#) Flexi-II Extraction Arm: 200mm (8")Ø – 3m (10')L.  
 [P-145](#) Flexi-II Extraction Arm: 200mm (8")Ø – 4m (14')L.  
 [P-146](#) Flexi-II Extraction Arm: 200mm (8")Ø – 5m (17')L.

**Misc. Options (when ordering main unit)**  
 [P-026](#) Wall Flex high efficiency filtration system c/w P-160 cartridge filter.

**"Self-Supporting" Hose WITHOUT Wire Helix**  
 [NH-KD-3](#) 3" diameter Economy Fume & Dust extractor. Must be connected to duct, wall bracket and/or capture hoods (not included) Sold per foot. Maximum self supporting length = 4'.  
 [NH-KD-4](#) 4" diameter Economy Fume & Dust extractor. Must be connected to duct, wall bracket and/or capture hoods (not included) Sold per foot. Maximum self supporting length = 4'.  
 [NH-KD-5](#) 5" diameter Economy Fume & Dust extractor. Must be connected to duct, wall bracket and/or capture hoods (not included) Sold per foot. Maximum self supporting length = 4'.

**Hose Connectors and Fittings**  
 [R-060](#) Inlet Ø125 galvanized, 8 bolts M8 x 16mm. Packed in plastic.  
 [R-061](#) Inlet Ø150/160 powder coated black, 8 bolts M8 x 16mm. Packed in plastic.  
 [R-062](#) Inlet Ø200 powder coated black, 8 bolts M8 x 16mm. Packed in plastic.  
 [R-063](#) Inlet Ø100 powder coated black, 8 bolts M8 x 16mm. Packed in plastic.  
 [R-064](#) Inlet Ø75 powder coated black, 8 bolts M8 x 16mm. Packed in plastic.

**Manual Motor Starter**  
 [P-024-1](#) 115V/1/60 Fan Motor control station. Permits manual start-stop of the fan. Comes complete with motor overload protection on/off 14A control power cord and plug. Overload rating according to the FLA of the motor. Field assembly & installation required.  
 [P-024-2](#) Fan Motor control station. Permits manual start-stop of the fan. Comes complete with motor overload protection and on/off control. 0.6-1.0A OVERLOAD ---> HP rating: 1/4@230/3/60, 1/2@460/3/60, 1/2@575/3/60  
 [P-024-3](#) Fan Motor control station. Permits manual start-stop of the fan. Comes complete with motor overload protection and on/off control. 1-1.6A OVERLOAD ---> HP rating: 1/3@230/3/60, 3/4@460/3/60, 1.0@575/3/60  
 [P-024-4](#) Fan Motor control station. Permits manual start-stop of the fan. Comes complete with motor overload protection and on/off control. 1.6-2.5A OVERLOAD ---> HP rating: 1/2@230/3/60, 1.0@460/3/60, 1.5@575/3/60  
 [P-024-5](#) Fan Motor control station. Permits manual start-stop of the fan. Comes complete with motor overload protection and on/off control. 2.5-4A OVERLOAD ---> HP rating: 1.0@230/3/60, 2.0@460/3/60, 3.0@575/3/60

03-05

CUSTOMER:  
 CUSTOMER P.O.:  
 PROJECT:  
 ENGINEER:  
 SALES REP.:  
 IDENTIFICATION / TAGGING:



The device depicted and described hereon embodies proprietary information owned by the manufacturer. All design, manufacturing, reproduction, sales and patent rights regarding this device or drawing reserved except where explicit right is guaranteed in writing. We reserve the right to make design changes.

Drawn by: Janos B  
 Date: 3/2/2010  
 Scale: NTS  
 Weight: N/A

**03-05 WALL-FLEX CARTRIDGE DUST COLLECTOR**  
 Specification Drawing  
 Drawing No.: - File Name: (03-05) Wall Flex - SD  
 Material: - Sheet: 3/4

# MODELS & OPTIONS:

## Fan, Light & Other Electrical Accessories

- [VFD-208/230V-1](#) Variable Frequency Drive for 1HP 208-230/1-3/60Hz motor
- [VFD-208/230V-1.5](#) Variable Frequency drive for 1.5HP 208-230/1-3/60Hz motor
- [VFD-208/230V-10](#) Variable Frequency drive for 10HP 208-230/1-3/60Hz motor
- [VFD-208/230V-15](#) Variable Frequency drive for 15HP 208-230/1-3/60Hz motor
- [VFD-208/230V-2](#) Variable Frequency drive for 2HP 208-230/1-3/60Hz motor
- [VFD-208/230V-20](#) Variable Frequency drive for 20HP 208-230/1-3/60Hz motor
- [VFD-208/230V-25](#) Variable Frequency drive for 25HP 208-230/1-3/60Hz motor
- [VFD-208/230V-3](#) Variable frequency drive for 3HP 208-230/1-3/60Hz motor
- [VFD-208/230V-30](#) Variable Frequency drive for 30HP 208-230/1-3/60Hz motor
- [VFD-208/230V-40](#) Variable Frequency drive for 40HP 208-230/1-3/60Hz motor
- [VFD-208/230V-5](#) Variable Frequency drive for 5HP 208-230/1-3/60Hz motor
- [VFD-208/230V-50](#) Variable Frequency drive for 50HP 208-230/1-3/60Hz motor
- [VFD-208/230V-7.5](#) Variable Frequency drive for 7.5HP 208-230/1-3/60Hz motor
- [VFD-480V-1](#) Variable Frequency drive for 1HP 480/3/60Hz motor
- [VFD-480V-1.5](#) Variable Frequency drive for 1.5HP 480/3/60Hz motor
- [VFD-480V-10](#) Variable Frequency drive for 10HP 480/3/60Hz motor
- [VFD-480V-15](#) Variable Frequency drive for a 15HP 480/3/60Hz motor
- [VFD-480V-2](#) Variable Frequency drive for 2HP 480/3/60Hz motor
- [VFD-480V-20](#) Variable Frequency drive for 20HP 480/3/60Hz motor
- [VFD-480V-25](#) Variable Frequency drive for 25HP 480/3/60Hz motor
- [VFD-480V-3](#) Variable Frequency drive for 3HP 480/3/60Hz motor
- [VFD-480V-30](#) Variable Frequency drive for 30HP 480/3/60Hz motor
- [VFD-480V-40](#) Variable Frequency drive for 40HP 480/3/60Hz motor
- [VFD-480V-5](#) Variable Frequency drive for 5HP 480/3/60Hz motor
- [VFD-480V-50](#) Variable Frequency drive for 50HP 480/3/60Hz motor
- [VFD-480V-7.5](#) Variable Frequency drive for 7.5HP 480/3/60Hz motor
- [VFD-575V-10](#) Variable Frequency drive for 10HP 575/3/60Hz motor
- [VFD-575V-15](#) Variable Frequency drive for 15HP 575/3/60Hz motor
- [VFD-575V-2](#) Variable Frequency drive for 2HP 575/3/60Hz motor
- [VFD-575V-20](#) Variable Frequency drive for 20HP 575/3/60Hz motor
- [VFD-575V-25](#) Variable Frequency drive for 25HP 575/3/60Hz motor
- [VFD-575V-3](#) Variable Frequency drive for 3HP 575/3/60Hz motor
- [VFD-575V-30](#) Variable Frequency drive for 30HP 575/3/60Hz motor
- [VFD-575V-40](#) Variable Frequency drive for 40HP 575/3/60Hz motor
- [VFD-575V-5](#) Variable Frequency drive for 5HP 575/3/60Hz motor
- [VFD-575V-50](#) GE Variable Frequency drive for 50HP 575/3/60Hz motor
- [VFD-575V-7.5](#) Variable Frequency drive for 7.5HP 575/3/60Hz motor

## Accessories

- [AL-6-PG-6](#) 0-6" magna-helic pressure gauge, approximately 5" diameter size. Surface mounted.

## Installation Accessories

- [P-086](#) Double arm Adapter, which permits 2-160mm Flexi arms to be mounted on Mobi-Flex or Wall-Flex.
- [PDK-8-DS](#) Industrial grade DESTRATIFICATION kit for destratifying heat and fugitive emissions.

## Filter Options

- [WF-HEPA-RETROFIT KIT](#) HEPA 99.97% @ 0.3 Micron Filter Retrofit Kit for existing Wall-Flex units

## Replacement filters - (Quantity discounts available upon request)

- [7FR0-3000](#) Cell/Poly Blend "Extended Media" Filter, 99% efficiency @ 0.5 microns. for Wall-Flex w/ Hopper (FH-160 filter holder required)
- [CF-45](#) Activated charcoal filter cartridge (filled with approx. 45 lbs. of activated charcoal)
- [CFH-4-6](#) Replacement Charcoal After Filter for Mobi & Wall Flex c/w 6lbs of Activated Carbon
- [Charcoal-15](#) 15 lbs. pail of activated carbon. \*\*\* Minimum Order quantity is 4 units when ordering separately. \*\*\*
- [P-004-WFC-16](#) Filter, Gas/Micro - Combo Filter - spun bond polyester/activated carbon (comes with 12-15 lbs. of activated charcoal in pale)
- [P-150-535-HEPA](#) Replacement HEPA After Filter for Mobi & Wall Flex
- [P-160](#) 80/20 Cell Polyester blended replacement filter cartridge for standard Mobi-Flex units **For Dry Dust & Welding smoke applications. Cleanable with a vacuum or compressed air.**
- [P-160-OEM](#) OEM Replacement filter for Mobi-Flex. Washable spun-bound polyester. Cleanable with Detergent and high pressure water.
- [P-160-TEF](#) Teflon Filter for Mobi Flex and Wall Flex filter units. 99.97% @ 0.5 Micons... Washable
- [P-160W](#) Washable spun-bound polyester replacement filter cartridge for standard Mobi-Flex units **for Oily smoke applications. Cleanable with Detergent and high pressure water.**

## Sound Attenuation

- [SIL-8](#) Silencer for P-Max series fan, 8" (200mm) (for use with P-Max Fans)

03-05

CUSTOMER:
CUSTOMER P.O.:
PROJECT:
ENGINEER:
SALES REP.:
IDENTIFICATION / TAGGING:



The device depicted and described hereon embodies proprietary information owned by the manufacturer. All design, manufacturing, reproduction, sales and patent rights regarding this device or drawing reserved except where explicit right is guaranteed in writing. We reserve the right to make design changes.

Drawn by:	Janos B
Date:	3/2/2010
Scale:	NTS
Weight:	N/A

<b>03-05 WALL-FLEX CARTRIDGE DUST COLLECTOR</b>	
Specification Drawing	
Drawing No.: -	File Name: (03-05) Wall Flex - SD
Material: -	Sheet: 4/4