

## SPECIFICATIONS:

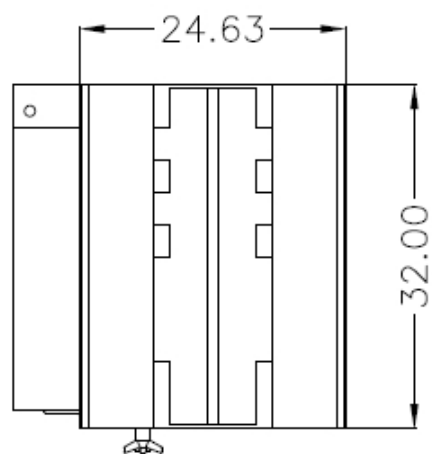

TOP VIEW  
(SHOWN LESS GRATE)

### CONSTRUCTION:

12/14/16 Gauge steel cabinet finished with Powder-Coat Finish. Includes a 5 gallon external dust drawer, 5" deep downdraft table with removable back fence, removable end cap for easy access to filter, removable panel for easy access to B.I. motor blower, 25' 12 Ga. power cord, and on-off switch. Motor wired to junction box outside unit for 3 phase. Acoustical lining standard in blower compartment. Vibra-Pulse cleaning standard.

### WEIGHT:

260 lbs.

### DOWNDRAFT VELOCITY:

112 FPM with std. 1 HP motor  
150 FPM with opt. 1.5 HP motor

### NOISE:

75 dBA

### ELECTRICAL:

- 1 HP 115 /1/60, 12 amps, std.
- 1.5 HP 115/208-230/1/60, 15/7.9-7.5 amps, opt.
- 1.5 HP 208-230/460/3/60, 4.9-4.6/2.3 amps, opt.

### FIRE SUPPRESSION:

Equipment provided by others.

### SPECIAL NOTES:

Compressed air filter provided by others.

### MAIN FILTERS:

- (1) Clean-2 cart., 16"dia. w/150 ft<sup>2</sup> media, std.
- (1) Cart. FIBERDUST 16"dia.w/75 ft<sup>2</sup> media, opt.
- (1) Cartridge, Spunbond, opt.
- (1) Cartridge, Spark Resistant, opt.
- (1) Cartr. Spunbond - HO, opt.
- (1) Cartridge, CleanPlus double treated fire retardent, opt.

### HEPA OPTION:

- (1) External HEPA filter, 99.97%

### AD OPTION:

- (1) External adsorber, 18 lb. capacity

### OTHER OPTIONS:

- Pressure gauge kit indicates filter changes
- Auto Clean
- Regulator
- Casters, increases table height by 3" to OA 36"
- BF3 w/Light
- Aluminum Grate
- Vinyl Grate
- Fiberglass Grate
- Silencer (Adds 8" to depth of unit)

\* AFS FILTER EFFICIENCIES BASED ON ASHRAE 52-76 TEST METHOD

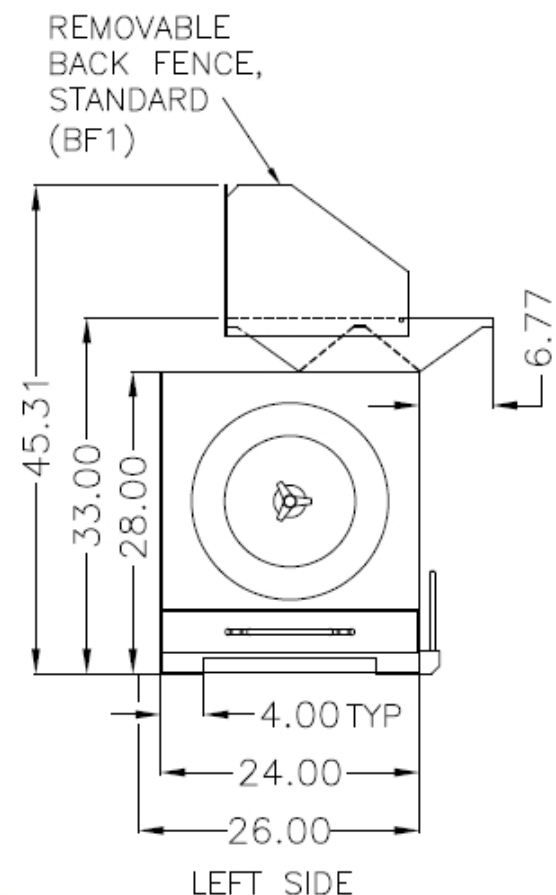

LEFT SIDE

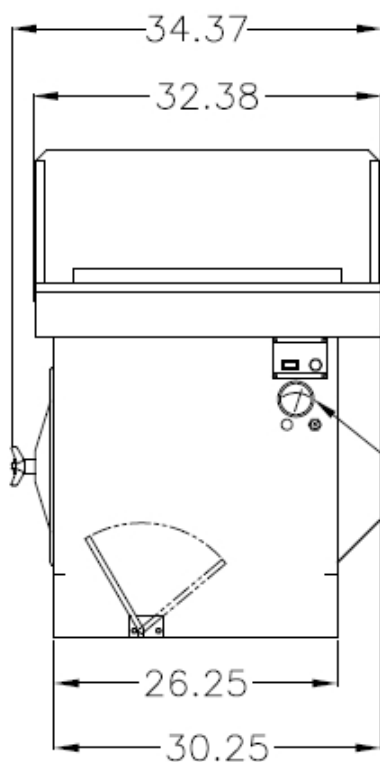

FRONT VIEW

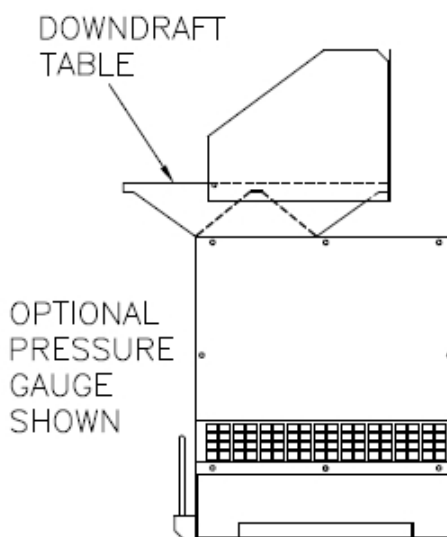

RIGHT SIDE

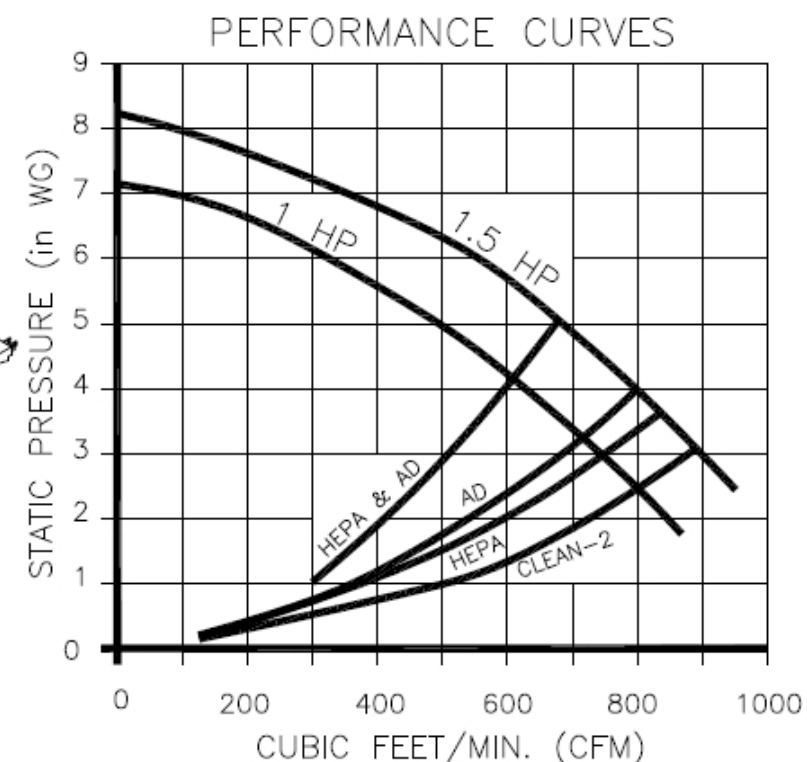
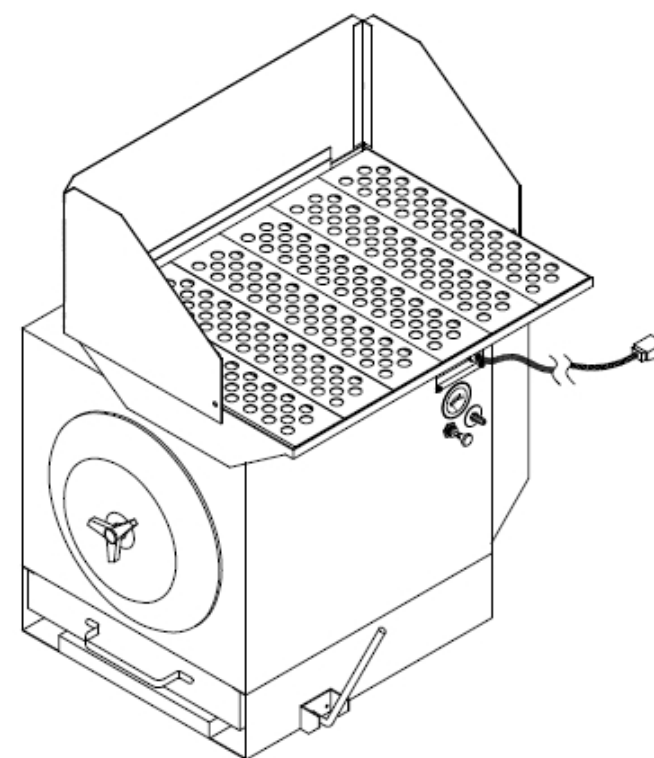

05-03

CUSTOMER:  
CUSTOMER P.O.:  
PROJECT:  
ENGINEER:  
SALES REP.:  
IDENTIFICATION / TAGGING:

> [www.lev-co.com](http://www.lev-co.com) • 1.888.862.5356

**lev-co**

The device depicted and described hereon embodies proprietary information owned by the manufacturer. All design, manufacturing, reproduction, sales and patent rights regarding this device or drawing reserved except where explicit right is guaranteed in writing. We reserve the right to make design changes.

Drawn by: Janos B  
Date: 5/1/2008  
Scale: NTS  
Weight: N/A

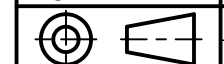

05-03 DTH-800  
Downdraft Table  
Specification Drawing  
Drawing No.: -  
File Name: (05-02) DTH-800 - SD  
Material: Product manufactured by:  
Sheet: 1/2

**Airflow**  
SYSTEMS INC.

**MODELS & OPTIONS:**

**Part # Description**

**Main System / Part**

- DTH800-1** 800 cfm downdraft table, 24" deep x 32" wide work surface at 33" height, 150 fpm downdraft velocity, with 12" tall removable side & back shields and painted steel grate panels. Contains (1) CLEAN-2® cartridge filter (150 sq.ft. of media), manual VIBRA-PULSE® filter cleaning systems, a 1HP TEFC motor, 115/230/1/60 Hz (12/6 amps), and a removable 5 gallon external dust drawer.71 dBA.
- DTH800-2** 800 cfm downdraft table, 24" deep x 32" wide work surface at 33" height, 150 fpm downdraft velocity, with 12" tall removable side & back shields and painted steel grate panels. Contains (1) CLEAN-2® cartridge filter (150 sq.ft. of media), manual VIBRA-PULSE® filter cleaning systems, a 1HP TEFC motor, 230/460/3/60 Hz (12/6 amps), and a removable 5 gallon external dust drawer.71 dBA.
- DTH800-3** 800 cfm downdraft table, 24" deep x 32" wide work surface at 33" height, 150 fpm downdraft velocity, with 12" tall removable side & back shields and painted steel grate panels. Contains (1) CLEAN-2® cartridge filter (150 sq.ft. of media), manual VIBRA-PULSE® filter cleaning systems, a 1HP TEFC motor, 575/3/60 Hz (12/6 amps), and a removable 5 gallon external dust drawer.71 dBA.

**Fan / Motor Upgrades or Options (when ordering main unit)**

- DTH800-HP-1** 1.5 Hp TEFC motor, 115/208-230/1/60 Hz, high pressure, spark resistant, backward incline blower. 900 cfm. 150 fpm downdraft velocity.(15/7.9-7.5 amps). 74 dBA.
- DTH800-HP-3** 1.5 Hp TEFC motor, 208-230/460/575/3/60 Hz, high pressure, spark resistant, backward incline blower. 900 cfm. 170 fpm downdraft velocity. (4.9-4.6/2.3 amps).
- MOTOR-EXP-1.5-F&G-3PH** Three Phase, non-sparking blower wheel & hazardous location (group F & G) motor option. Option comes complete with dust tight conduit connections and terminates in a dust tight enclosure on the exterior of the Collector. Please note that this option should not be used in "Hazardous Location" environments. Please specify voltage when ordering.
- MOTOR-EXP-1.5-F&G-1PH** Single Phase, non-sparking blower wheel & hazardous location (group F & G) motor option. Option comes complete with dust tight conduit connections and terminates in a dust tight enclosure on the exterior of the Collector. Please note that this option should not be used in "Hazardous Location" environments. Please specify voltage when ordering.

**Filter Options (when ordering main unit)**

- DTH800-AD** Internal AD option: AD cartridge (15 lbs. capacity) with 1" polyester prefilter and afterfilter in place of CLEAN-2® cartridge and VIBRA-PULSE® cleaning system. Order charcoal separately.
- DTH800-EXAD** External adsorber module. 18 lbs. capacity; 550/650 cfm. Order charcoal separately. (Adds 4" to overall depth and 10 lbs. to ship weight).
- DTH800-EXDOP** External DOP, 95%, 550/650 cfm. (Adds 4" to overall depth and 10 lbs. to ship weight)
- DTH800-EXHE** External HEPA, 99.97%, 550/650 cfm. (Adds 4" to overall depth and 10 lbs. to ship weight)
- DTH800-UCP** UltraClean Plus Cartridge Filter Option for Standard DTH-800 Unit
- DTH800- EXT HE/AD** Kit using EXTERNAL HEPA and EXTERNAL AD options.

**Preventative Maintenance Pressure Gauges, etc. (when ordering main unit)**

- DTH800-PG-6** 0-6" magna-helic pressure gauge, approximately 5" diameter size. Surface mounted.
- DTH800-REG** Regulator Gauge Option for Standard DTH-800 Unit

**Sound Attenuation**

- DTH800-S-EXT** External Silencer Option for Standard DTH-800 Unit

**Localized Enclosures and Shields**

- DTH800-BF3/LIGHT** Enclosure, 36" high, with sides, back and top, plus 40 watt, Dust-Tite, 115 volt work light. Replaces standard 12" tall side & back shields
- DT-EN-1** Aluminum/Acrylic enclosure c/w top back and side acrylic panels for improved visibility & capture of fumes and dust (3'H X 32"W X 24"D)

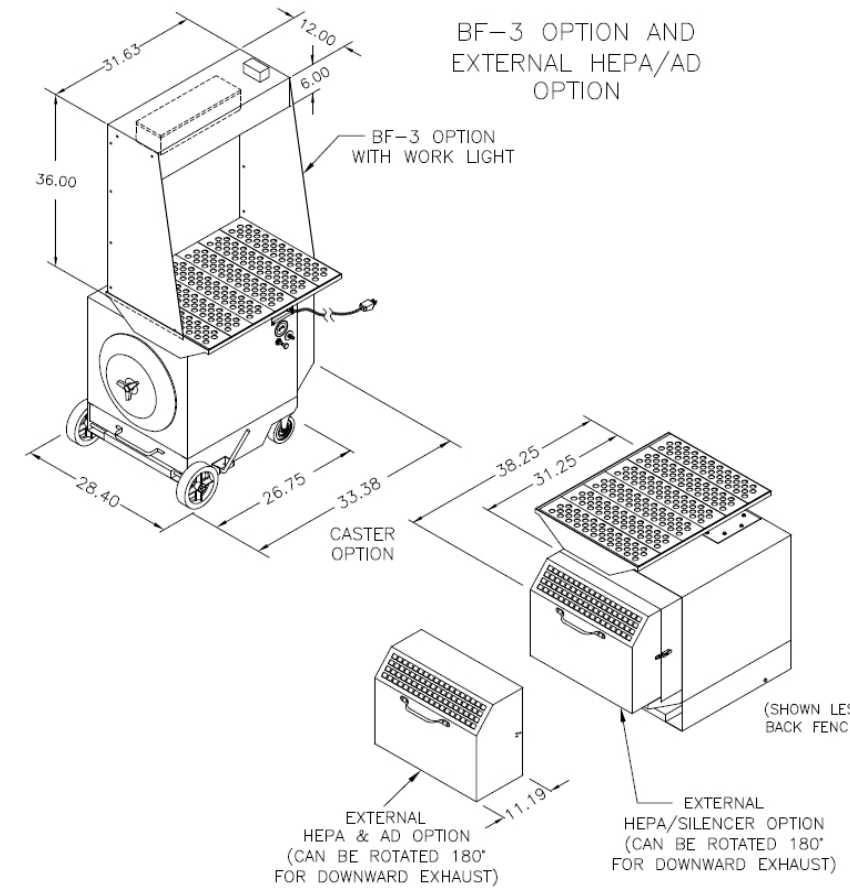

**Fan, Light & Other Electrical Accessories**

- DTH800-AP-1** Off line AUTO-CLEAN® cleaning system, 115v only 1 phase. Automatically clean filter when unit is turned off. 230v 1@ price will be same as AP-3.
- DTH800-AP-3** Off line AUTO-CLEAN® cleaning system, 3 phase. Automatically clean filter when unit is turned off.

**Misc. Options (when ordering main unit)**

- DTH800-ALUM** Aluminum grate panels in place of steel grate panels.
- DTH800-CASTERS** Adds 8" fixed wheels on front, 5" swivel casters on rear, and full width handle. (Adds 3.25" to table height).
- DTH800-COATED** Vinyl Coated Bar Grate Option for Standard DTH-800 Unit
- DTH800-FIBER** Fiberglass Bar Grates Option for Standard DTH-800 Unit
- DTH800-TABLE EXT** Table extension, full width with solid surface, 9" deep.
- DCH-1-EXPVENT** Explosion Vent door for single cartridge collectors. (PCH-1, ALH-1, DCH-1, DTH-1,DS-1 & Mini-Pac.
- DTH800-STEEL** Steel grate in place of standard panels.

**Retro-Fit Parts**

- 2KT51733** External HEPA Retrofit Kit for PCH-1, PCH-2, DCH-1, DCH-2, DTH-800, DTH-1700
- 2KT51734** External AD Retrofit Kit for PCH-1, PCH-2, DCH-1, DCH-2, DTH-800, DTH-1700. Charcoal not Included. Please order charcoal separately.
- 2KT51739** External HEPA & AD Retrofit Kit for PCH-1, PCH-2, DCH-1, DCH-2, DTH-800, DTH-1700. Charcoal not included. Please order charcoal separately.
- 2KT51768** External Silencer Retrofit Kit for PCH-1, PCH-2, DCH-1, DCH-2, DTH-800, DTH-1700

**05-03**

CUSTOMER:  
 CUSTOMER P.O.:  
 PROJECT:  
 ENGINEER:  
 SALES REP.:  
 IDENTIFICATION / TAGGING:

[www.lev-co.com](http://www.lev-co.com) • 1.888.862.5356

The device depicted and described hereon embodies proprietary information owned by the manufacturer. All design, manufacturing, reproduction, sales and patent rights regarding this device or drawing reserved except where explicit right is guaranteed in writing. We reserve the right to make design changes.

Drawn by: Janos B  
 Date: 5/1/2008  
 Scale: NTS  
 Weight: N/A

**05-03 DTH-800**  
**Downdraft Table**  
**Specification Drawing**

Drawing No.: -      File Name: (05-02) DTH-800 - SD  
 Material:      Product manufactured by:      Sheet: 2/2