

TOP VIEW

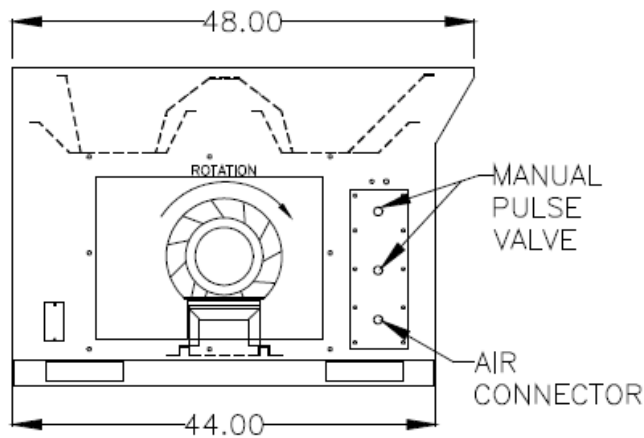

LEFT SIDE VIEW

(ELECTRICAL CONNECTION THIS END. EXACT LOCATION VARIES DEPENDING ON OPTIONS.)

**NOTES:**

ITEMS DESIGNATED AS  ARE INCLUDED IN THIS PROPOSAL.

**CONSTRUCTION:** 10, 12, and 14 Gauge steel cabinet with Powder-Coat finish. Includes separate access covers for filters and removable dust tray, 11.88 sq. ft., heavy duty, 300 PSF rated steel grating (max. table loading 1500 lbs.; concentrated load 400 lbs.), baffled inlet spark trap, Vibra-Pulse® filter cleaning system, and a direct drive motor/blower assembly wired to junction box outside unit. Motor starters/disconnects NOT included.

**WEIGHT:** 850 lbs.

**DOWNDRAFT VELOCITY:** 200 FPM (3 HP)  
250 FPM (5 HP)

**AIRFLOW:** 3000 CFM (3 HP)  
3750 CFM (5 HP)

**ELECTRICAL:**  3 HP 208-230/460/3/60, 9.2-8.0/4.0 amps, std.  
 3 HP 230/1, 14.5 amps, opt.  
 5 HP 230/460/3/60, 12.0/6.0 amps, opt.

**NOISE:** 77 dBA (worker zone) / 81 dBA @ 5' (outlet area), std., 3 HP  
74 dBA (worker zone) / 78 dBA @ 5' (outlet area), silencer, 3 HP  
78 dBA (worker zone) / 80 dBA @ 5' (outlet area), silencer stack, opt., 5 HP

**FIRE SUPPRESSION:** Equipment provided by others.

**SPECIFICATIONS:**

**MAIN FILTERS:**  (6) 150 ft<sup>2</sup> Clean 2® filters, 16" Dia., std.  
 (6) FiberDust® cartridges, opt.

**AFTER FILTERS:**  Extended Life HEPA option  
 Extended Life DOP option

**OTHER OPTIONS:**  Pressure gauge kit indicates filter changes  
 Casters  
 BF-1, Side shield option  
 BF-2, Side shield option (24" center divider)  
 BF-3, Hood option  
 Fiberglass grating  
 Aluminum grating  
 PVC coated grating  
 Heavy duty grate, 1.5 x .25 bars, 1032 lbs. concentrated load. Max table load, 2000 lbs.  
 Auto-Clean System  
 Silencer, with or without stack collar

**SPECIAL NOTES:** Compressed air filter provided by others.

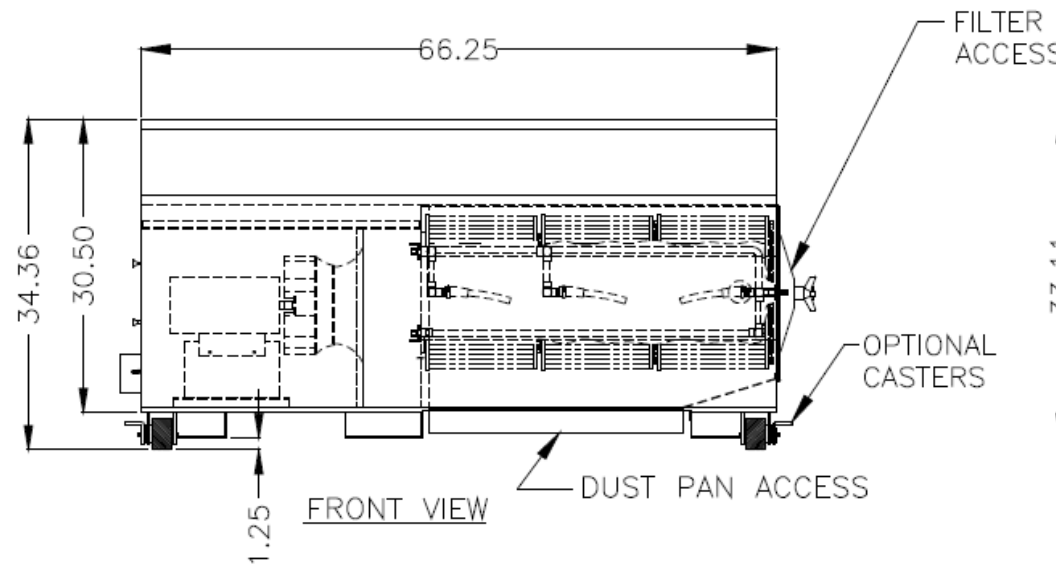

FRONT VIEW

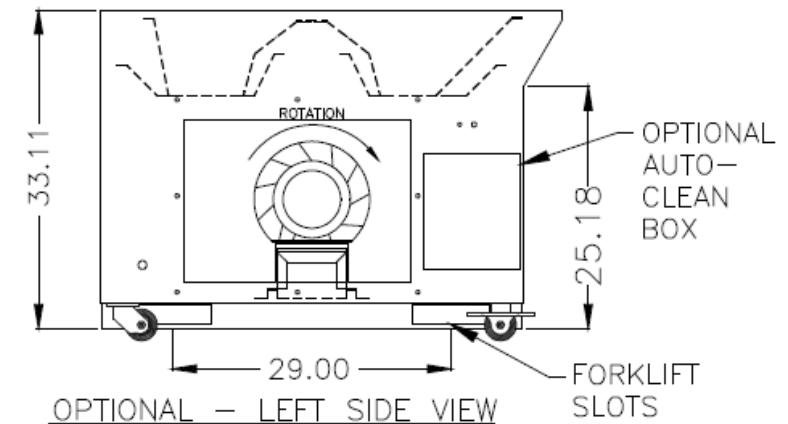

OPTIONAL - LEFT SIDE VIEW

05-05

CUSTOMER:	
CUSTOMER P.O.:	
PROJECT:	
ENGINEER:	
SALES REP.:	
IDENTIFICATION / TAGGING:	

[www.lev-co.com](http://www.lev-co.com) • 1.888.862.5356



The device depicted and described hereon embodies proprietary information owned by the manufacturer. All design, manufacturing, reproduction, sales and patent rights regarding this device or drawing reserved except where explicit right is guaranteed in writing. We reserve the right to make design changes.

Drawn by:	Janos B
Date:	7/23/2010
Scale:	NTS
Weight:	N/A

<b>05-05 DT3000V2</b>	
<b>Downdraft Table</b>	
<b>Specification Drawing</b>	
Drawing No.:	-
File Name:	(05-05) DT3000V2 - SD
Material:	-
Sheet:	1/5

# SIDE SHIELD OPTIONS

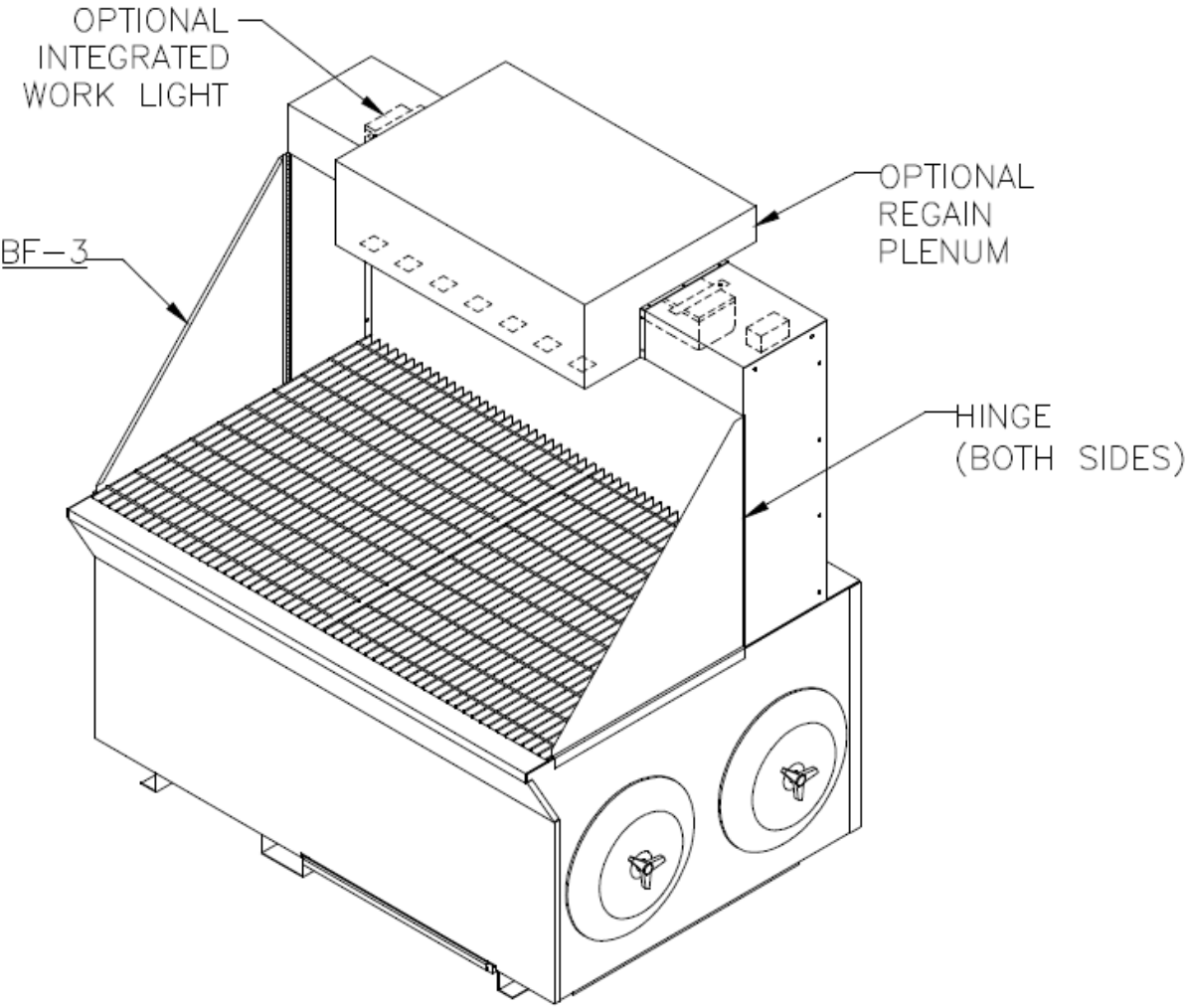
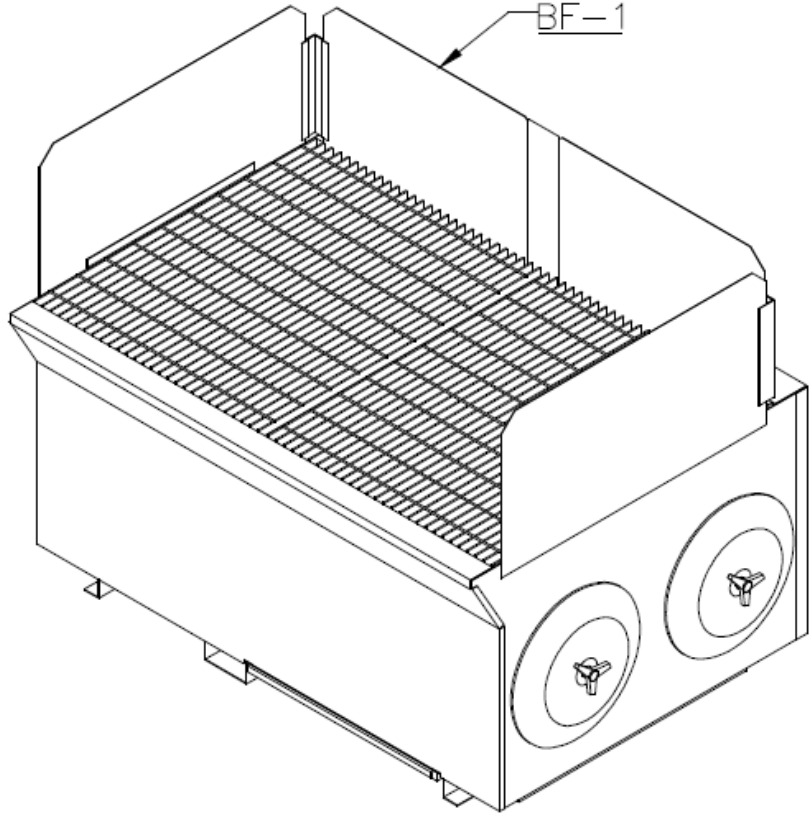
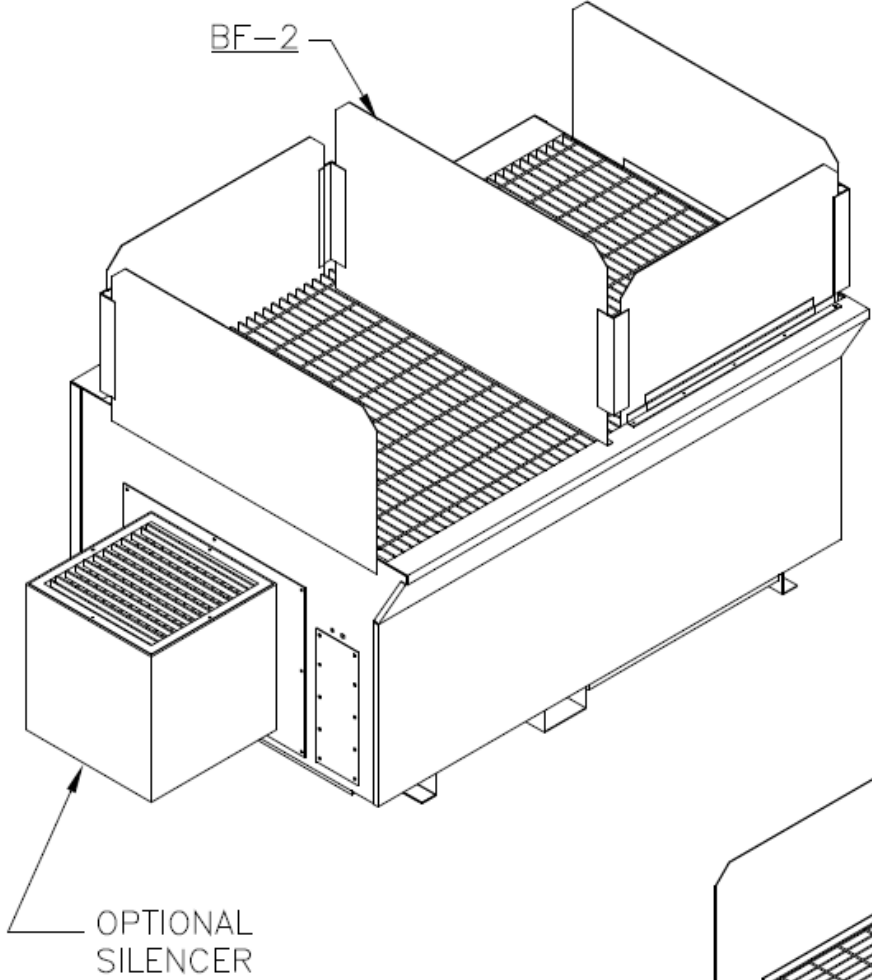

05-05

CUSTOMER:
CUSTOMER P.O.:
PROJECT:
ENGINEER:
SALES REP.:
IDENTIFICATION / TAGGING:

[www.lev-co.com](http://www.lev-co.com) • 1.888.862.5356



The device depicted and described hereon embodies proprietary information owned by the manufacturer. All design, manufacturing, reproduction, sales and patent rights regarding this device or drawing reserved except where explicit right is guaranteed in writing. We reserve the right to make design changes.

Drawn by:	Janos B
Date:	7/23/2010
Scale:	NTS
Weight:	N/A

<b>05-05 DT3000V2</b>	
<b>Downdraft Table</b>	
<b>Specification Drawing</b>	
Drawing No.: -	File Name: (05-05) DT3000V2 - SD
Material: -	Sheet: 2/5

# EXTERNAL HEPA OPTION

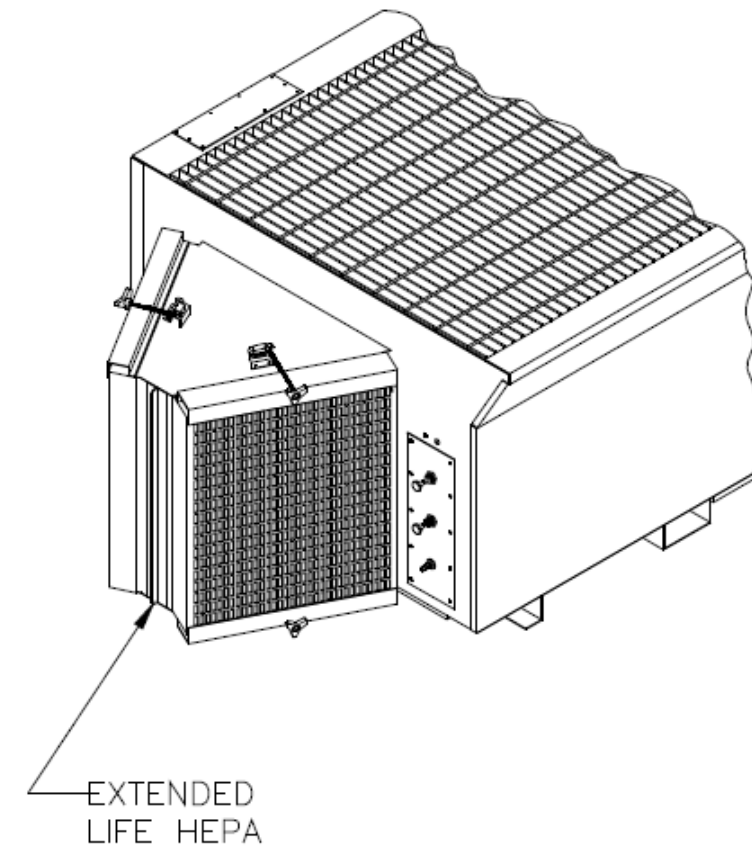
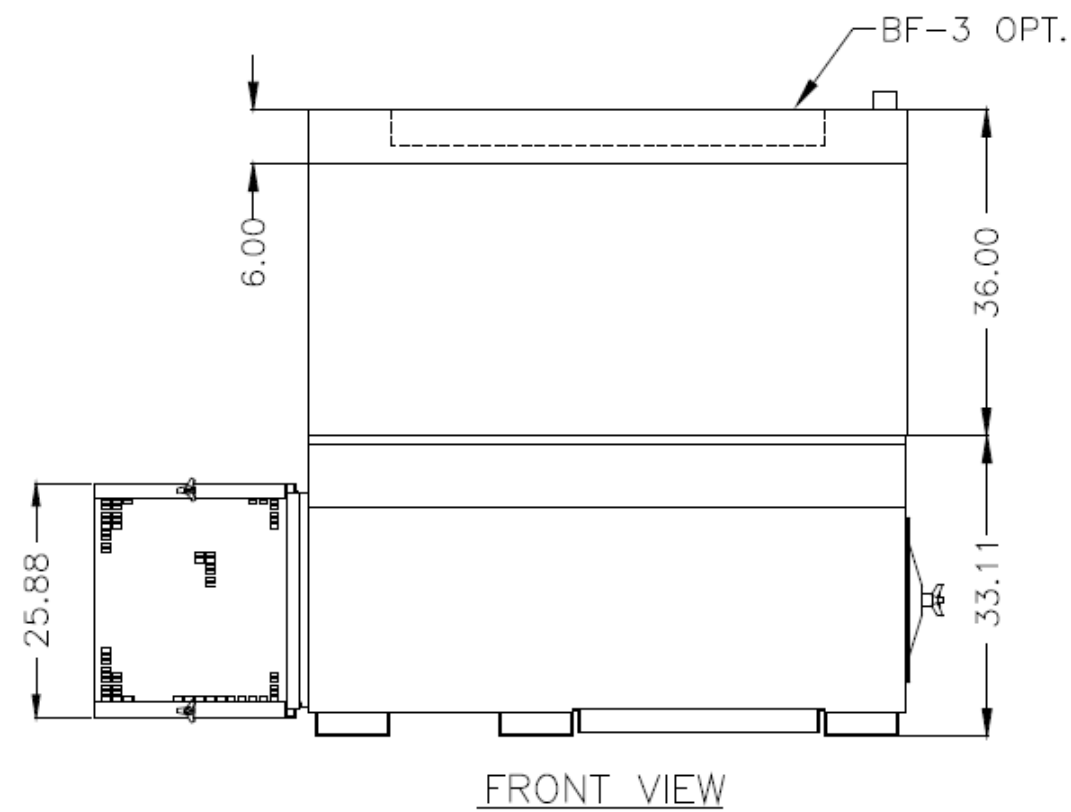
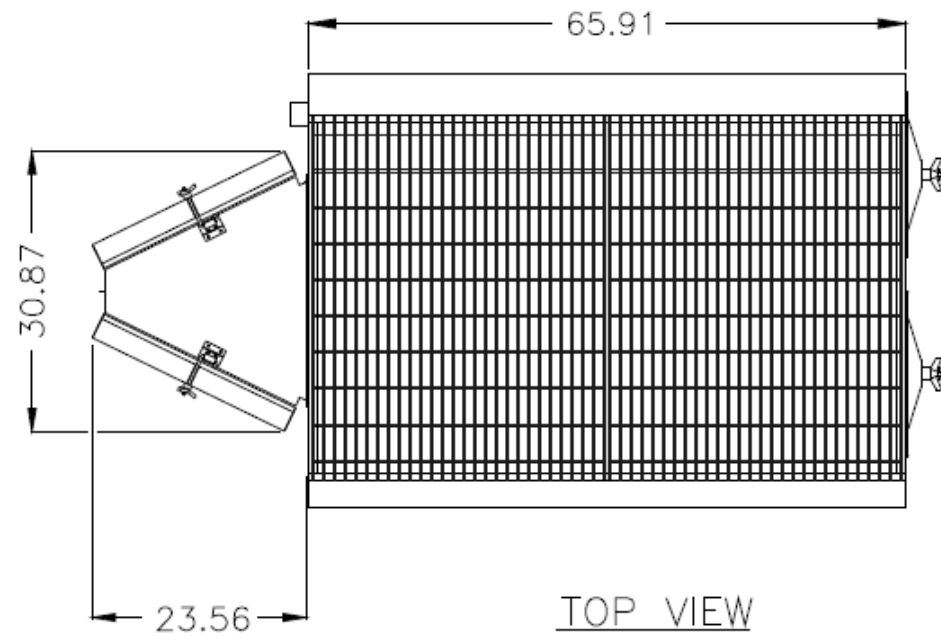

05-05

CUSTOMER:  
CUSTOMER P.O.:  
PROJECT:  
ENGINEER:  
SALES REP.:  
IDENTIFICATION / TAGGING:

> [www.lev-co.com](http://www.lev-co.com) • 1.888.862.5356

**lev-co**

The device depicted and described hereon embodies proprietary information owned by the manufacturer. All design, manufacturing, reproduction, sales and patent rights regarding this device or drawing reserved except where explicit right is guaranteed in writing. We reserve the right to make design changes.

Drawn by: Janos B  
Date: 7/23/2010  
Scale: NTS  
Weight: N/A

**05-05 DT3000V2  
Downdraft Table**

Specification Drawing

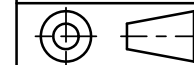

Drawing No.: -  
Material: -  
File Name: (05-05) DT3000V2 - SD  
Sheet: 3/5

**SHOP INSTRUCTION: HOW TO MODIFY THE DT3000 TO ACCEPT EXTERNAL HEPA OR AD.**

**KIT NUMBER: 2AU45703 & 2AU45705**  
**INSTRUCTION NUMBER: 9ME45712**

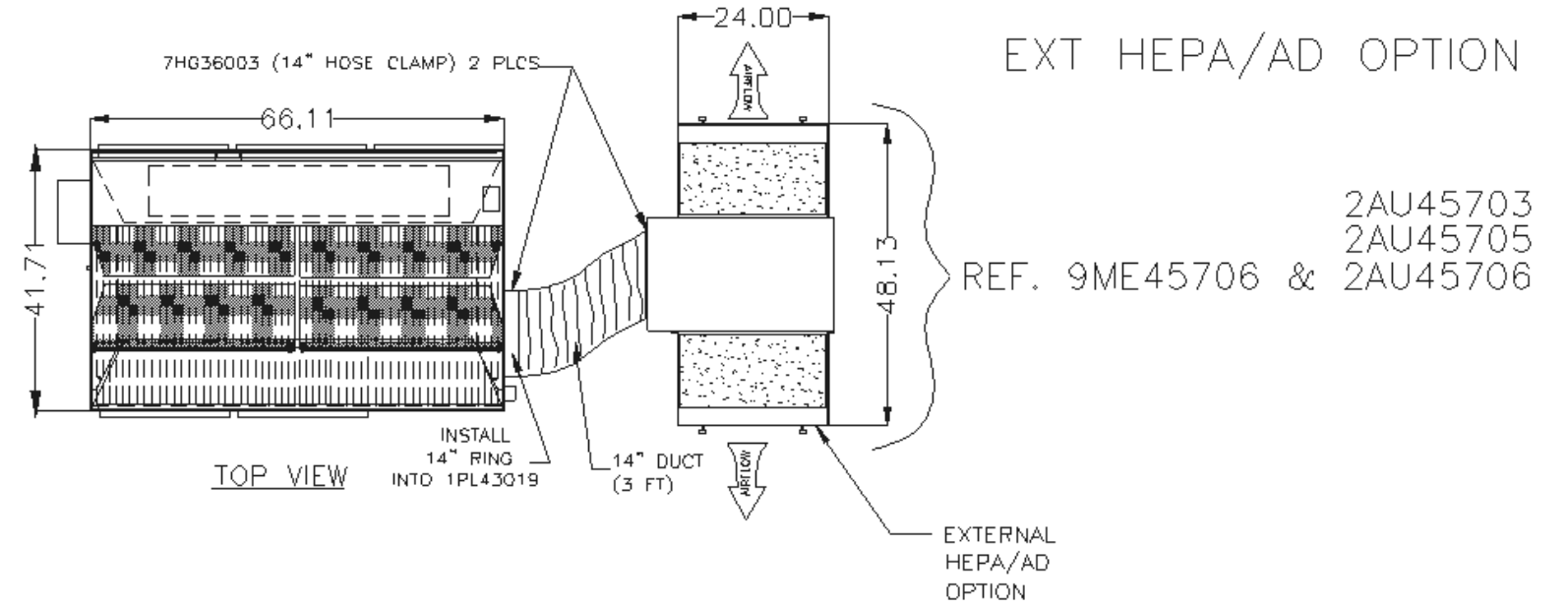

**GENERAL**

This sheet will explain how the DT3000 is to be modified to accept the external hepa. 2AU45706.

**INSTRUCTIONS**

1. Install 14" ring into blank plate, p/n : 1PL43019.
2. Install plate with ring over blower exhaust at right end of DT3000 onto cabinet.
3. Install 14" hose & hose clamps to ring installed in step #2 above and attach other end to HEPA/AD option cabinet.

**\*\*14" DUCT REMOVED FOR SHIPPING**

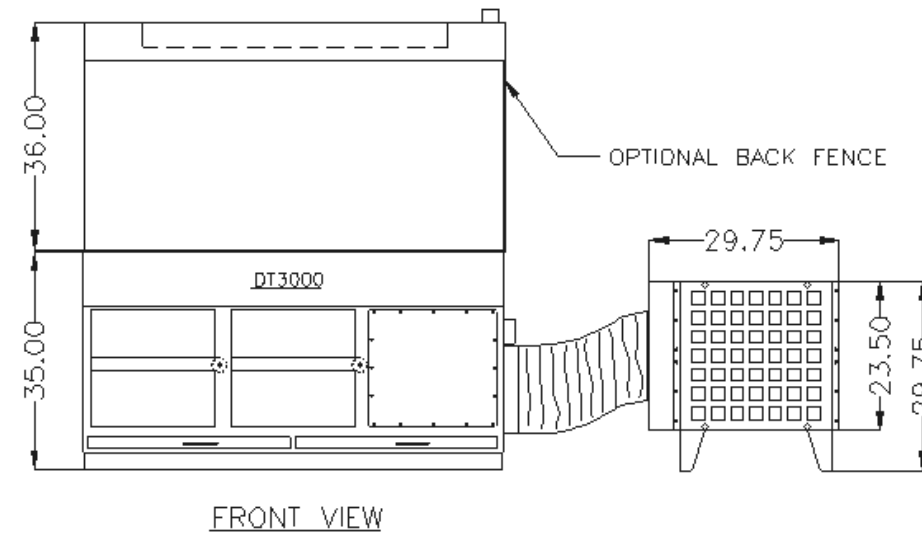

**05-05**

CUSTOMER:	
CUSTOMER P.O.:	
PROJECT:	
ENGINEER:	
SALES REP.:	
IDENTIFICATION / TAGGING:	

[www.lev-co.com](http://www.lev-co.com) • 1.888.862.5356



The device depicted and described hereon embodies proprietary information owned by the manufacturer. All design, manufacturing, reproduction, sales and patent rights regarding this device or drawing reserved except where explicit right is guaranteed in writing. We reserve the right to make design changes.

Drawn by:	Janos B
Date:	7/23/2010
Scale:	NTS
Weight:	N/A

<b>05-05 DT3000V2</b>	
<b>Downdraft Table</b>	
<b>Specification Drawing</b>	
Drawing No.:	-
File Name:	(05-05) DT3000V2 - SD
Material:	-
Sheet:	4/5

**MODELS & OPTIONS:**

**Main System / Part**

[DT3000-V2.0](#) 3000 cfm heavy duty downdraft table, 42 deep x 66 wide work surface at 33 height, 200 fpm downdraft velocity, with baffled inlet spark trap. Contains (6) CLEAN-2® cartridge filters (150 sq.ft. of media), manual VIBRA-PULSE® filter cleaning system and a

**Fan / Motor Upgrades or Options (when ordering main unit)**

[DT3000V2-3HP-1 PHASE](#) 3 Hp 115/1/60 Hz (14.5 amps) 74 dBA (worker zone 78 dBA @ 5' (outlet area) in place of std. 3Hp motor  
 [DT3000V2-5HP](#) 5 Hp TEFC motor, 230/460/575/3/60Hz (12/6 amps), high pressure blower; 3750 cfm, 195 fpm downdraft velocity.

**Filter Options (when ordering main unit)**

[DT3000V2-EXAD](#) External AD option: includes (4) refillable, v-bank adsorber modules, 100 lbs. capacity in remote cabinet. Order charcoal separately (see specification sheet for size).  
 [DT3000V2-EXHE](#) External HEPA option: includes (2) 99.97% HEPA filters in separate remote cabinet (see specification sheet for size).

**Misc. Options (when ordering main unit)**

[DT3000V2-ALUM](#) Aluminum bar grate in place of painted steel bar grate.  
 [DT3000V2-AP3](#) Offline AUTO-CLEAN VIBRA-PULSE cleaning system, 3 phase. Automatically cleans filters when unit is turned off. Call factory before ordering.  
 [DT3000V2-COATED](#) Vinyl coated steel bar grate in place of painted steel bar grate.  
 [DT3000V2-FIBER](#) Fiberglass bar grate in place of painted steel bar grate.  
 [DT3000V2-REG](#) Regulator, 1/2" NPT full flow, adjustable, mounted and plumbed.  
 [DT3000V2-REGAIN](#) Regain air option to redirect 500 CFM back in to the work area to increase capture. To be used with the BF3 option.

**Accessories**

[DT3000V2-EXT-FRONT](#) Table extension, front, full width with solid surface. 9" deep  
 [DT3000V2-EXT-LEFT](#) Table extension, left side, full width with solid surface. 9" deep.  
 [DT3000V2-EXT-RIGHT](#) Table extension, right side, full width with solid surface. 9" deep

**Installation Accessories**

[DT3000V2-BF1](#) Back fence for one operator using entire table. Four (4) interchangeable rear and side panels, 18" high.  
 [DT3000V2-BF2](#) Additional single center divider, 24" high for use with BF1. Separates table in half for 2 operators.  
 [DT3000V2-BF3](#) Enclosure 36" tall, with sides, back and top.  
 [DT3000V2-BF3/LIGHT](#) BF3 enclosure with 80 watt, Dust-Tite 115 volt work light.  
 [DT3000V2-BF3-ACRILIC](#) Enclosure 36" tall, with side, back and top. Clear Acrylic  
 [DT3000V2-CASTERS](#) Heavy duty with two (2) swivel casters and two (2) rigid casters with locks. Raises table height 1"  
 [SIL-3000](#) Silencer for the DDT. Reduces noise output from table. 84" in length by 20" dia.(16" at inlet and outlet)

**Replacement filters - (Quantity discounts available upon request)**

[7FR02020 - PTFE](#) Cartridge filter PTFE Polyester media for PCH/DCH/DTH units  
 [7FR0-2020-OEM](#) Cartridge, CLEAN-2®, 150 sq.ft. of media. Replacement Filter for DCH/PCH/DTH, TC-4, HC-4, DC-4/6/8/12/18 & DT-3000V2 filter units  
 [7FR0-5020](#) UCP Cartridge Filter ALH-1/2/6, DCH, PCH, DTH, Mobi-Pulse, DC-4/6/8/12/18, TC-4 HC-4 & DT-3000V2.  
 [CF-7FR0-2020](#) Flame Retardant Cartridge Filter made of 80/20% Cell/Poly Blend., Replacement Filter for DCH/PCH/DTH, TC-4, HC-4, DC-4/6/8/12/18 & DT-3000V2 filter units.  
 [CF-7FR0-2029](#) Cartridge filter, Spunbond, Spark-resistant. Replacement Filter for DCH/PCH/DTH, TC-4, HC-4, DC-4/6/8/12/18 & DT-3000V2 filter units.  
 [Charcoal-18](#) 18 lbs. of activated charcoal  
 [Charcoal-200](#) 200 lbs. drum of activated carbon.  
 [FL-7FJ9-9113](#) 99.97% @ 0.3 micron HEPA Filter, wood frame (24 x 24 x 12)

**Sound Attenuation**

[DT3000V2-S](#) External Silencer  
 [DT3000V2-S-ST](#) Exhaust silencer with stack adapter. Upward discharge silencer with round 16" collar to accommodate vertical exhaust ducting (duct not included).

**05-05**

CUSTOMER:
CUSTOMER P.O.:
PROJECT:
ENGINEER:
SALES REP.:
IDENTIFICATION / TAGGING:



The device depicted and described hereon embodies proprietary information owned by the manufacturer. All design, manufacturing, reproduction, sales and patent rights regarding this device or drawing reserved except where explicit right is guaranteed in writing. We reserve the right to make design changes.

Drawn by:	Janos B
Date:	7/23/2010
Scale:	NTS
Weight:	N/A

<b>05-05 DT3000V2 Downdraft Table</b>	
<b>Specification Drawing</b>	
Drawing No.: -	File Name: (05-05) DT3000V2 - SD
Material: -	Sheet: 5/5