

SPECIFICATIONS:

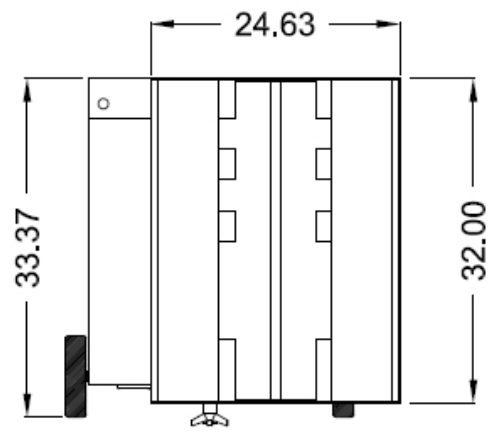

TOP VIEW
(SHOWN LESS GRATE)

CONSTRUCTION: 12/14/16 Gauge steel cabinet finished with Powder-Coat Finish. Includes a 5 gallon external dust drawer, 5" deep aluminum downdraft table with removable aluminum back fence, removable end cap for easy access to filter, removable panel for easy access to B.I. motor/blower, 8" wheels, 5" casters, 25', 12 Ga. power cord, and on-off switch. Motor wired to junction box outside of unit for 3 phase. Acoustical lining standard in blower compartment. Aluminum grating standard.

WEIGHT: 280 lbs.

DOWNDRAFT VELOCITY: 112 FPM with std. 1 HP motor
160 FPM with opt. 1.5 HP motor

NOISE: 75 dBA

ELECTRICAL: 1 HP 115 /1/60, 12 amps, std. Class II Group E
 1.5 HP 208-230/460/3/60, 4.9-4.6/2.3 amps, opt. Class II Group E

FIRE SUPPRESSION: Equipment provided by others.

MAIN FILTERS: (1) UltraClean-Plus Cartridge Filter

AFTER FILTERS: (1) External HEPA filter, 99.97%, Opt.
 (1) External DOP filter, 95%, Opt.
 (1) External adsorber, 18 lb. capacity, Opt.

OTHER OPTIONS: Pressure gauge kit indicates filter changes
 BF3A
 Fiberglass grate
 Silencer (Adds 8" to depth of unit)

SPECIAL NOTES: Meets NFPA 651 for processing and finishing aluminum when properly used and maintained. (See standard for additional requirements.)

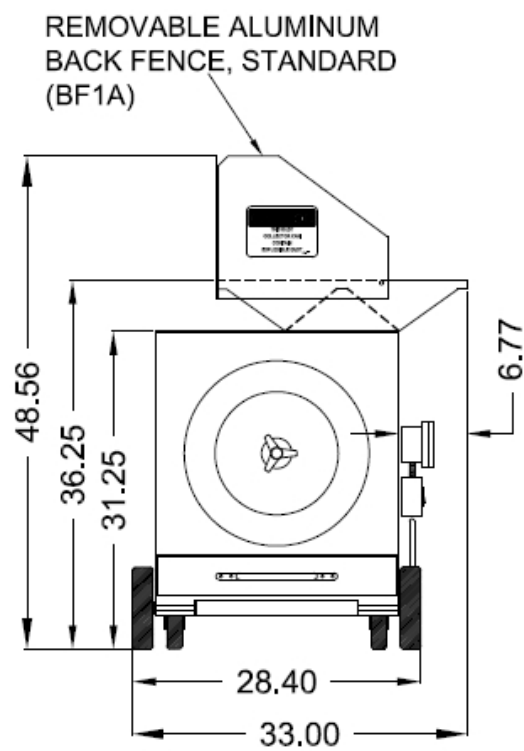

LEFT SIDE

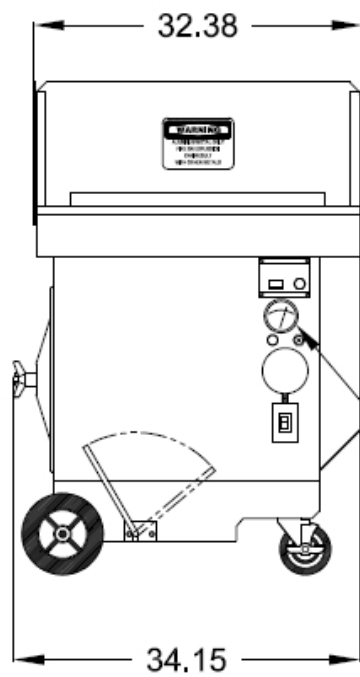

FRONT VIEW

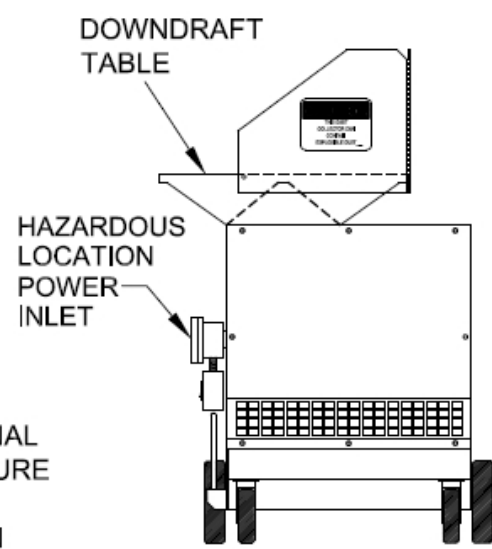

RIGHT SIDE

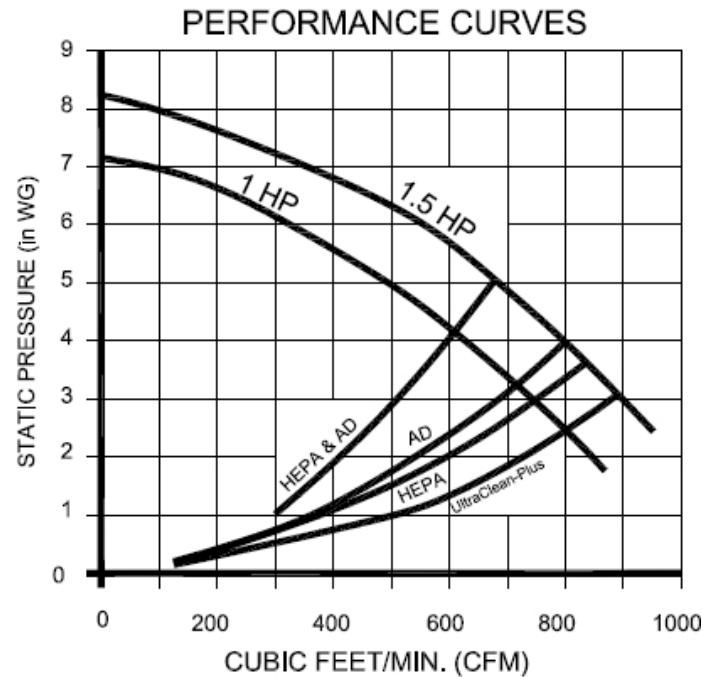
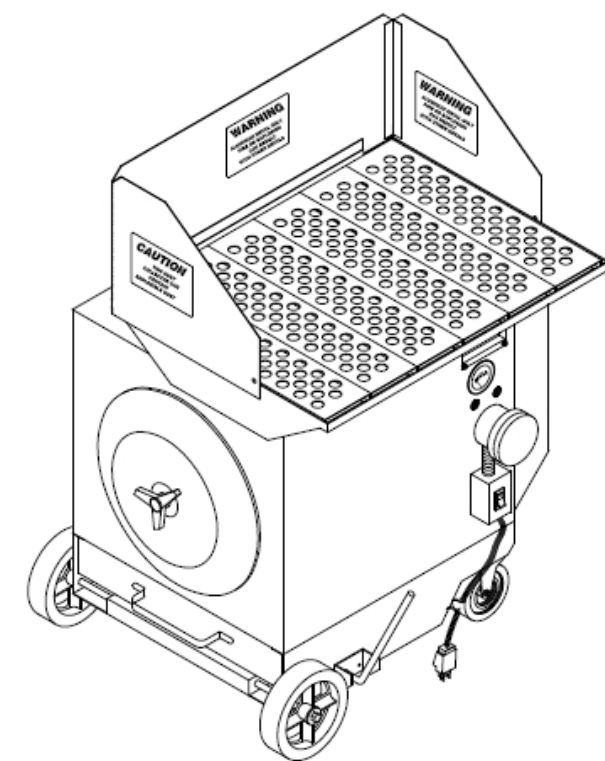

05-06

| | |
|---------------------------|--|
| CUSTOMER: | |
| CUSTOMER P.O.: | |
| PROJECT: | |
| ENGINEER: | |
| SALES REP.: | |
| IDENTIFICATION / TAGGING: | |

www.lev-co.com • 1.888.862.5356



The device depicted and described hereon embodies proprietary information owned by the manufacturer. All design, manufacturing, reproduction, sales and patent rights regarding this device or drawing reserved except where explicit right is guaranteed in writing. We reserve the right to make design changes.

| | |
|-----------|----------|
| Drawn by: | Janos B |
| Date: | 5/5/2008 |
| Scale: | NTS |
| Weight: | N/A |

05-06 ALH1
Downdraft Table
Specification Drawing

Drawing No.: - File Name: (05-06) ALH1 - SD
Material: Product manufactured by: **Airflow SYSTEMS INC.** Sheet: 1/2

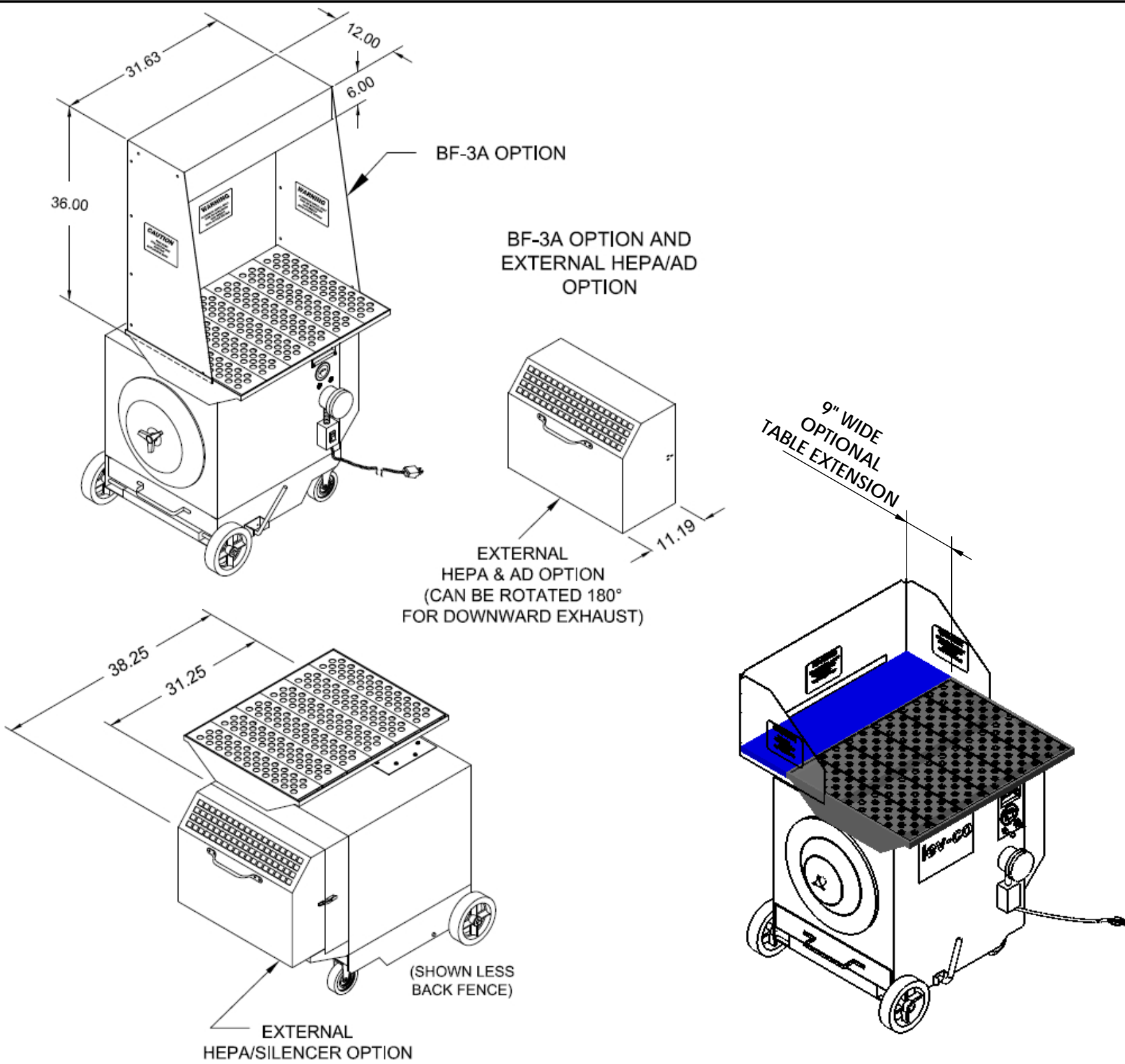

MODELS & OPTIONS:

| Part # | Description |
|---|--|
| Main System / Part | |
| <input type="checkbox"/> ALH1-1 | 800 cfm portable downdraft table to collect aluminum dust, 24" deep x 32" wide work surface at 36.25" height. 150 fpm downdraft velocity, with 12" tall aluminum side & back shields and aluminum grate panels. Contains (1) ULTRACLEAN-PLUS™ cartridge filter. (150 sq.ft.) and a 1 Hp Class II, Group E motor. 115/230/1/60 Hz (12/6 amps). Electrical components meet NFPA requirements for Class II, Group-E. (ALUMINUM DUST). 71 dBA |
| <input type="checkbox"/> ALH1-2 | 800 cfm portable downdraft table to collect aluminum dust, 24" deep x 32" wide work surface at 36.25" height. 150 fpm downdraft velocity, with 12" tall aluminum side & back shields and aluminum grate panels. Contains (1) ULTRACLEAN-PLUS™ cartridge filter. (150 sq.ft.) and a 1 Hp Class II, Group E motor. 230/460/3/60 Hz (12/6 amps). Electrical components meet NFPA requirements for Class II, Group-E. (ALUMINUM DUST). 71 dBA. |
| <input type="checkbox"/> ALH1-3 | 800 cfm portable downdraft table to collect aluminum dust, 24" deep x 32" wide work surface at 36.25" height. 150 fpm downdraft velocity, with 12" tall aluminum side & back shields and aluminum grate panels. Contains (1) ULTRACLEAN-PLUS™ cartridge filter. (150 sq.ft.) and a 1 Hp Class II, Group E motor. 5753/60 Hz (12/6 amps). Electrical components meet NFPA requirements for Class II, Group-E. (ALUMINUM DUST). 71 dBA. |
| Fan / Motor Upgrades or Options (when ordering main unit) | |
| <input type="checkbox"/> ALH1-HP-3 | 1.5 Hp Hazardous Location, Class II, Grp E 208-208/460/3/60 Option for Standard ALH-1 Unit |
| Filter Options (when ordering main unit) | |
| <input type="checkbox"/> ALH1-EXAD | External AD Module Filter Option for Standard ALH-1 Unit |
| <input type="checkbox"/> ALH1-EXDOP | External 95% DOP Filter Option for Standard ALH-1 Unit |
| <input type="checkbox"/> ALH1-EXHE | External 99.97% HEPA Filter Option for Standard ALH-1 Unit |
| <input type="checkbox"/> ALH1-HE/AD | Kit using EXTERNAL HEPA and EXTERNAL AD options. |
| Preventative Maintenance Pressure Gauges, etc. (when ordering main unit) | |
| <input type="checkbox"/> ALH1-PG-6 | 0-6" magna-helic pressure gauge, approximately 5" diameter size. Surface mounted. |
| Misc. Options | |
| <input type="checkbox"/> 2KT6-1760-ALH1 | Table extension painted blue for ALH-1, full width with solid surface, 9" deep |
| Sound Attenuation | |
| <input type="checkbox"/> ALH1-S-EXT | External Silencer Option for Standard ALH-1 Unit |
| Localized Enclosures and Shields | |
| <input type="checkbox"/> ALH1-BF3A | Aluminum Enclosure, 36" High, Sides, Back & Top Option for Standard ALH-1 Unit |
| Installation Accessories | |
| <input type="checkbox"/> ALH-INLET-6OR8 | Duct connection inlet for ALH-1 or ALH-2. Unit is delivered without the standard table top surface and instead it is equipped with a 6" or 8" collar for duct. Please specify duct diameter when ordering. |

05-06

| |
|---------------------------|
| CUSTOMER: |
| CUSTOMER P.O.: |
| PROJECT: |
| ENGINEER: |
| SALES REP.: |
| IDENTIFICATION / TAGGING: |

www.lev-co.com • 1.888.862.5356
 

The device depicted and described hereon embodies proprietary information owned by the manufacturer. All design, manufacturing, reproduction, sales and patent rights regarding this device or drawing reserved except where explicit right is guaranteed in writing. We reserve the right to make design changes.

| | |
|-----------|----------|
| Drawn by: | Janos B |
| Date: | 5/5/2008 |
| Scale: | NTS |
| Weight: | N/A |

| | |
|---|------------------------------|
| 05-06 ALH1 Downdraft Table | |
| Specification Drawing | |
| Drawing No.: | File Name: (05-06) ALH1 - SD |
| Material: | Product manufactured by: |
|  | |
| Sheet: 2/2 | |