

SPECIFICATIONS:

CONSTRUCTION: 10, 12, and 14 Gauge steel cabinet with Powder-Coat finish. Includes separate access covers for filters and removable dust tray, 11.88 sq. ft., heavy duty, aluminum grating (224 PSF/ 1000 lbs. total table loading), aluminum side shields, and a direct drive motor/blower assembly wired to junction box outside unit. Motor starters/disconnects NOT included.

WEIGHT: 850 lbs.

DOWNDRAFT

VELOCITY: 155 FPM

ELECTRICAL: 3 HP 208-230/460/3/60, 9.2-8.0/4.0 amps, Class II, Group E

NOISE: 77 dBA (worker zone) / 81 dBA @ 5' (outlet area)
74 dBA (worker zone) / 78 dBA @ 5' (outlet area), with silencer

MAIN FILTERS: (6) UltraClean-Plus cartridge™ filters

OTHER OPTIONS: Pressure gauge kit indicates filter changes
 Casters
 BF-2A, Side shield option (24" center divider)
 BF-3A, Hood option
 Fiberglass grating
 Silencer, with or without stack collar

SPECIAL NOTES: Meets NFPA 651 for processing and finishing aluminum when properly used and maintained. (See standard for additional requirements.)

FIRE SUPPRESSION: Equipment provided by others.

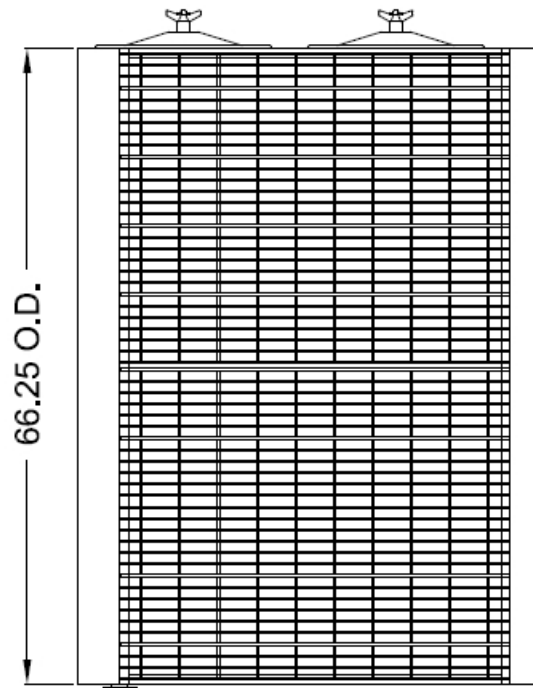

TOP VIEW

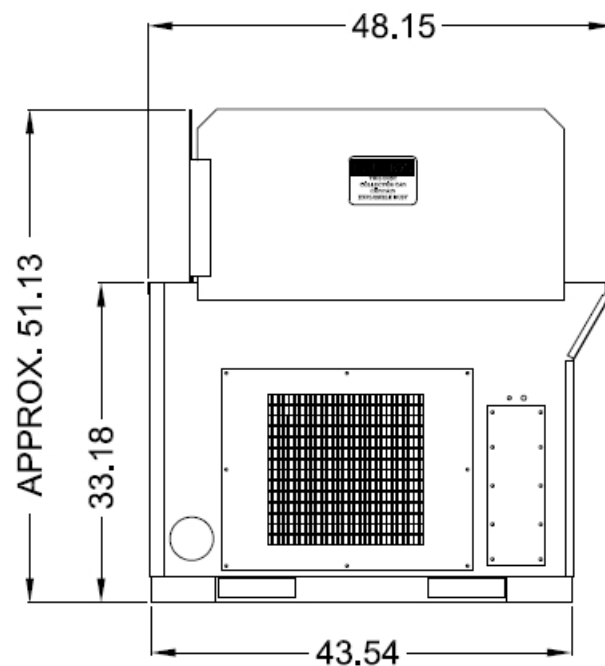

LEFT SIDE VIEW

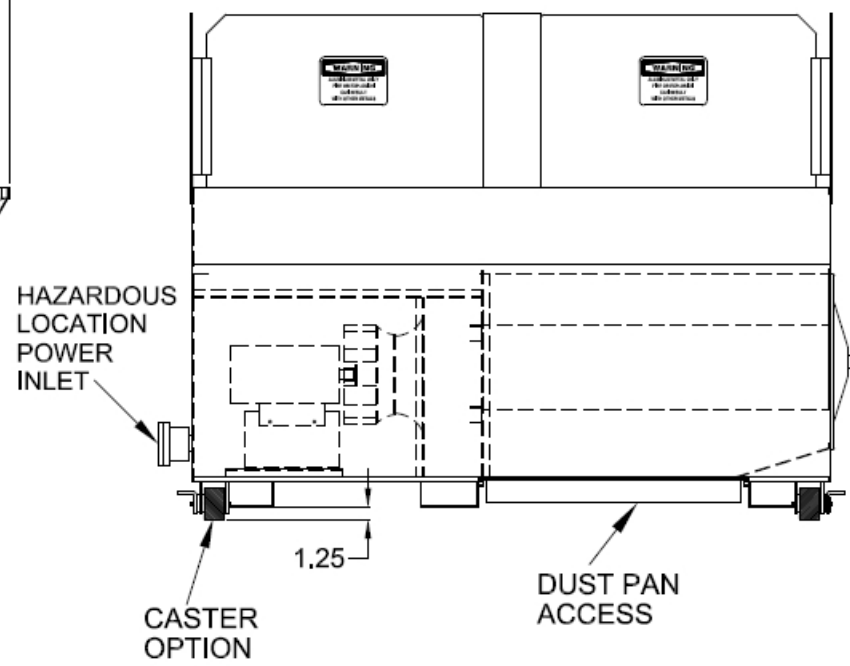

FRONT VIEW

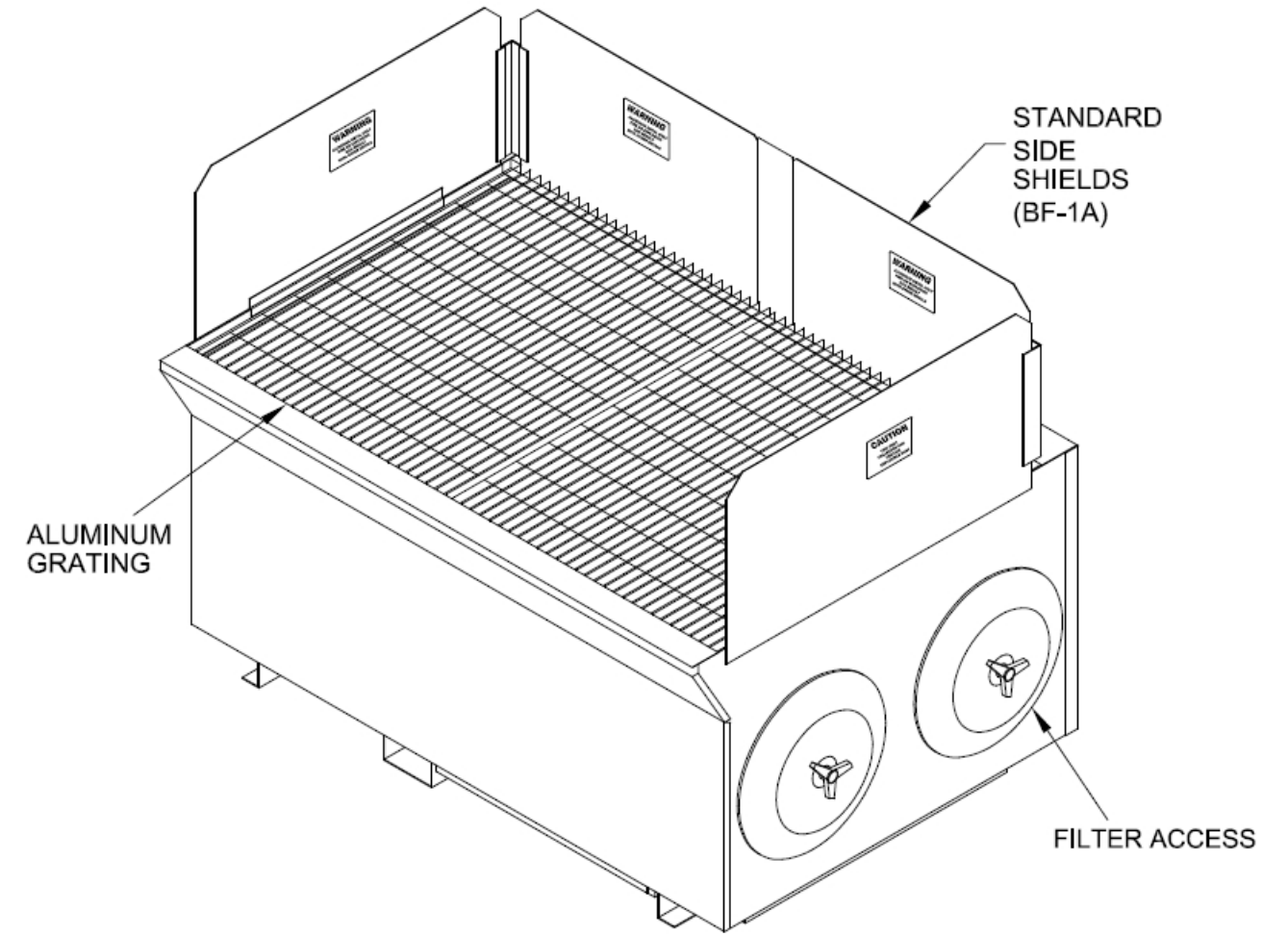

05-08

CUSTOMER:
CUSTOMER P.O.:
PROJECT:
ENGINEER:
SALES REP.:
IDENTIFICATION / TAGGING:

> www.lev-co.com • 1.888.862.5356



The device depicted and described hereon embodies proprietary information owned by the manufacturer. All design, manufacturing, reproduction, sales and patent rights regarding this device or drawing reserved except where explicit right is guaranteed in writing. We reserve the right to make design changes.

Drawn by:	Janos B
Date:	5/1/2008
Scale:	NTS
Weight:	N/A

05-08 AL6 Downdraft Table	
Specification Drawing	
Drawing No.: -	File Name: (05-08) AL6 - SD
Material:	Product manufactured by:
Sheet: 1/2	

BF-2A OPTION
(24" CENTER DIVIDER;
REQUIRES BF-1)

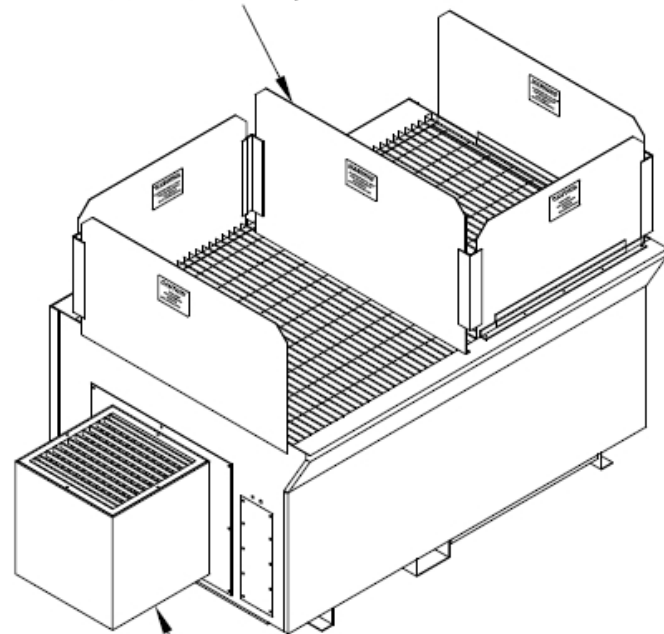

SIDE SHIELD AND SILENCER OPTIONS

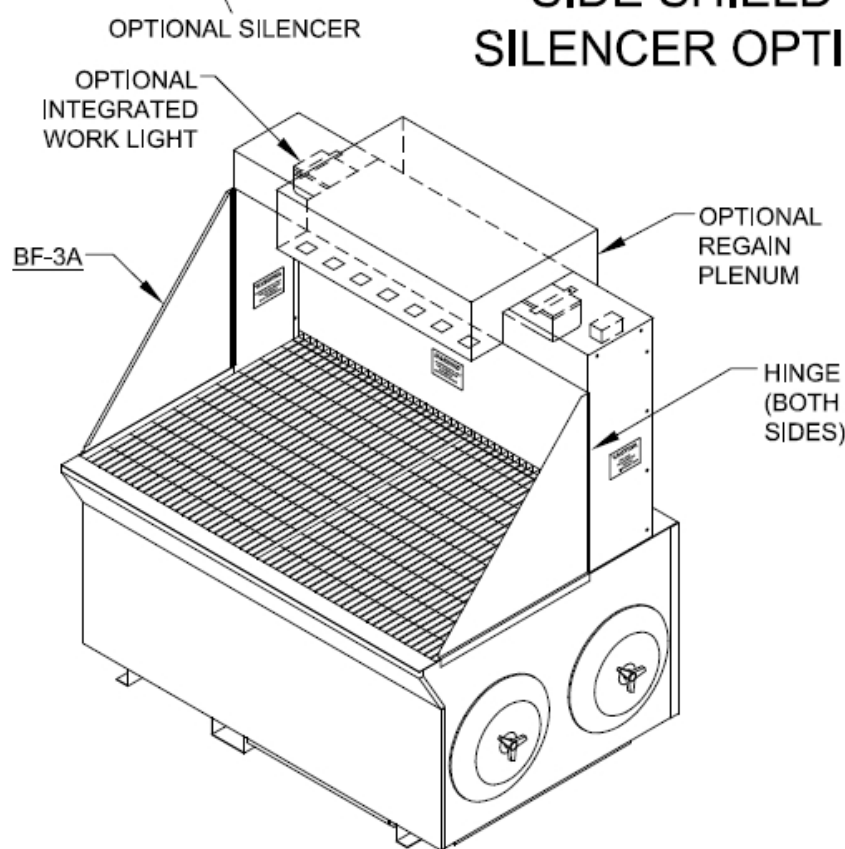

MODELS & OPTIONS:

Part #	Description
Main System / Part	
<input type="checkbox"/> AL6-1	3000 cfm heavy duty downdraft table to collect aluminum dust, 24" deep x 66" wide work surface at 33" height. 200 fpm downdraft velocity, with 18" tall aluminum side & back shields, casters, aluminum grate. (224 lbs. per sq.ft./1500 total table loading), (6) ULTRACLEAN-PLUS™ cartridge filters. (150 sq.ft. each) and a 3 Hp Group E motor. 208-230/460/3/60 Hz (9.2-8.0/4.0 amps) Class II Group-E. Electrical components meet NFPA 651 for processing and finishing aluminum when property used and maintained. 77 dBA (worker zone) / 81 dBA @ 5" (outlet area).
<input type="checkbox"/> AL6-2	3000 cfm heavy duty downdraft table to collect aluminum dust, 24" deep x 66" wide work surface at 33" height. 200 fpm downdraft velocity, with 18" tall aluminum side & back shields, casters, aluminum grate. (224 lbs. per sq.ft./1500 total table loading), (6) ULTRACLEAN-PLUS™ cartridge filters. (150 sq.ft. each) and a 3 Hp Group E motor. 575/3/60 Hz (9.2-8.0/4.0 amps) Class II Group-E. Electrical components meet NFPA 651 for processing and finishing aluminum when property used and maintained. 77 dBA (worker zone) / 81 dBA @ 5" (outlet area).
Preventative Maintenance Pressure Gauges, etc. (when ordering main unit)	
<input type="checkbox"/> AL6-PG-6	0-6" magna-helic pressure gauge, approximately 5" diameter size. Surface mounted.
Misc. Options	
<input type="checkbox"/> AL6-FIBER	Fiberglass bar grate in place of aluminum bar grate.
Sound Attenuation	
<input type="checkbox"/> AL6-S-EXT	Exhaust silencer with right angle discharge. For AL6 & DT3000V2 units.
<input type="checkbox"/> AL6-S-ST	Exhaust silencer with stack adapter. Upward discharge silencer with round 16" dia. collar to accommodate vertical exhaust ducting (duct supplied by others). For AL6 & DT3000V2 units.
Installation Option & Accessories	
<input type="checkbox"/> AL6-BF2A	Single 24" tall aluminum center divider for use with standard side & back shields. Divider separates table in half for two operators.
<input type="checkbox"/> AL6-BF3A	Aluminum enclosure 36" tall with sides back and top (replaces standard side & back shields)
<input type="checkbox"/> AL6-REGAIN	Regain air option to redirect 500 cfm back in to the work area to increase capture. To be used with the BF3 option.

05-08

CUSTOMER:
CUSTOMER P.O.:
PROJECT:
ENGINEER:
SALES REP.:
IDENTIFICATION / TAGGING:

> www.lev-co.com • 1.888.862.5356



The device depicted and described hereon embodies proprietary information owned by the manufacturer. All design, manufacturing, reproduction, sales and patent rights regarding this device or drawing reserved except where explicit right is guaranteed in writing. We reserve the right to make design changes.

Drawn by:	Janos B
Date:	5/1/2008
Scale:	NTS
Weight:	N/A

05-08 AL6 Downdraft Table	
Specification Drawing	
Drawing No.: -	File Name: (05-08) AL6 - SD
Material:	Product manufactured by: Airflow SYSTEMS INC.
Sheet: 2/2	