

## Easy Bench™



## Standard Panel Filter Industrial Downdraft Table

**Easy Bench™** – A downdraft table designed for the operator.

**A Perfect Fit.** Standard desk height with full leg room for maximum comfort and concentration.

**Simple Source Capture.** Removes dust, fumes, and odors, for a cleaner, healthier work environment, and improved productivity for close, fine hand work.

**Easy Filter Access.** Standard panels slide in and out from the front, with easy-seal magnetic covers.

05-01

05-01 EASY BENCH

### Industrial Applications:

- Deburring
- Grinding
- Inspection
- Powders
- Surface Finishing
- Buffing
- Hand Work
- Fine Sanding

### Features & Benefits:

- One-piece top with back-splash, air inlet holes across the main work area, and solid section in the rear for tools and supplies.
- Seamless integration of back-splash guard on three sides means no crevices to trap dirt, making cleaning easy.
- Top lifts off for access to catch-tray underneath. Larger particles or small tools that fall through the holes are trapped in the catch-tray.
- The high-tech reverse mounted motor/impeller is the secret to the strong airflow, quiet operation and compact design.
- Two full-size 24 x 24 x 4 filters allow for low filter velocity and high dust holding capacity.
- The leg room of the table is comparable to that of a well-designed office desk. The block of leg space is 26" H x 24" W x 14" D.
- The 800 CFM inlet air velocity ensures thorough dust collection.



## Easy Bench™

*A fine accessory for fine work.*

### Specifications:

- Air Flow.....800 CFM
- Construction.....14/16 ga. welded steel, powder-coated white cabinet. Easy-seal magnetic covers for easy access to filters. On/off switch. Acoustical lined blower compartment. Extra-long 8' power cord.
- Weight.....175 lbs.
- Sound Level.....66dBA
- Motor/Blower.....All-aluminum BCC (backward centrifugal curved) blower wheel runs at 1720 RPM rated UL, CSA
- Electrical.....115/1/60, 185 watts
- Work Surface.....24" x 36" with fall-through catch-tray below
- Filters.....(two) 24"x24"x4"
- Standard Efficiency.....MERV 11
- Optional Efficiency.....MERV 13, MERV 14, HEPA

### Options:

- Height: 28" and 32" available
- Casters
- Soft Mat Cover
- Odor Adsorption Filter
- Clear Acrylic Backsplash Extension to 16"

### Dimensions:

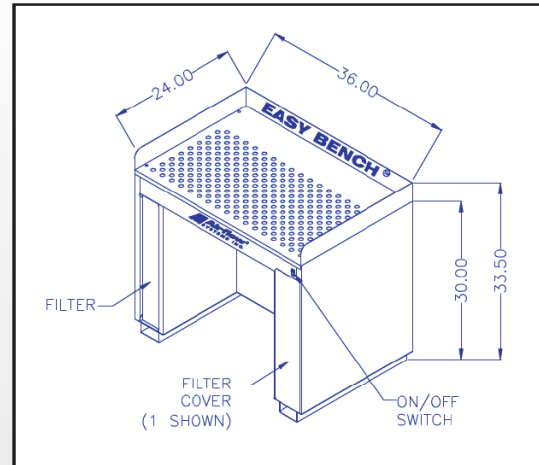

- Height.....30"
- Width.....36"
- Height to Top of Backsplash.....34"
- Depth.....24"
- Work Surface.....24" x 36"
- Leg Space:
- Height.....26"
- Width.....24"
- Depth.....14"

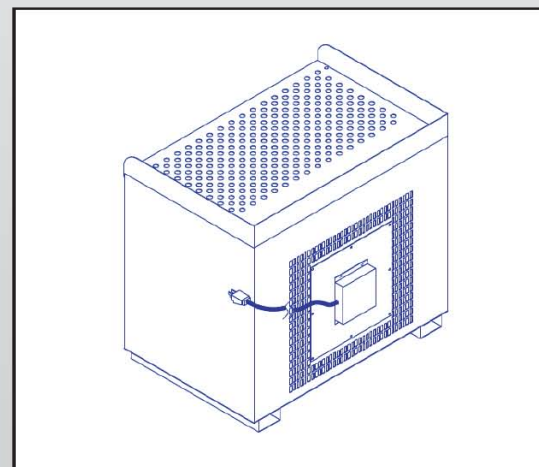

05-01 EASY BENCH

05-01