

06-06 BACKDRAFT HOODS

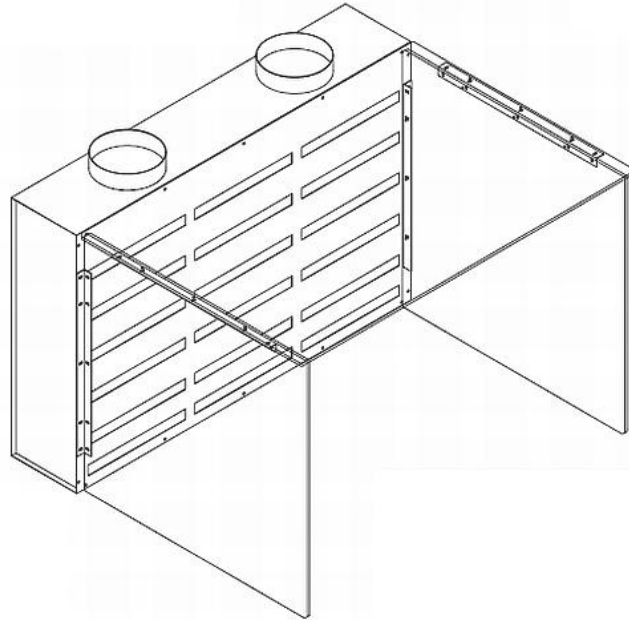
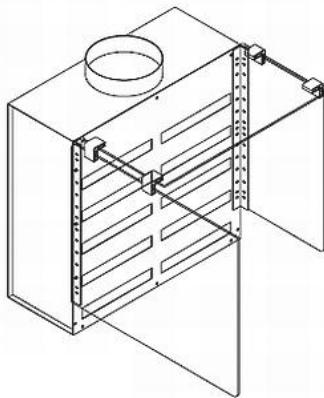

06-06

SPECIFICATIONS:

CONSTRUCTION:

2AH09003 – 20 Gauge welded steel, slotted backdraft hood with a Powder-Coat finish. 18"x18"x7" with (1) 6" diameter collar. 525 CFM recommended air volume.

2AC85001 – 20 Gauge welded steel, slotted backdraft hood with a Powder-Coat finish. 36"x24"x7" with (2) 6" diameter collars. 1050 CFM recommended air volume.

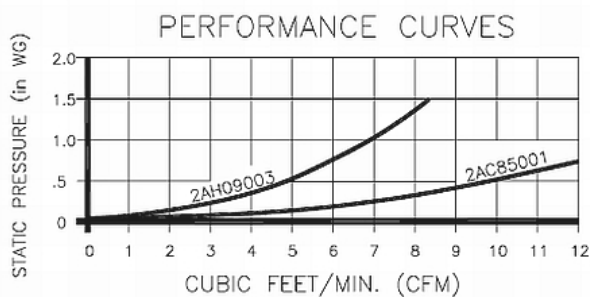

OPTIONS:

- Additional inlet collar
- 2KT92016 – Acrylic side shield kit. Left side extends 18", right side and top extend 9". Used on small backdraft hood.
- 2KT92026 – Acrylic side shield kit. Top, left, and right sides extend 24". Used on large backdraft hood.