

TOP VIEW

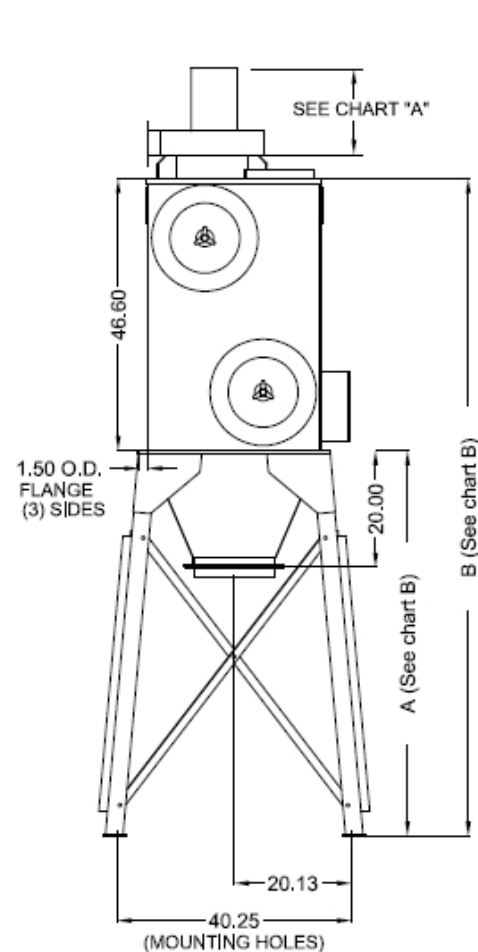

FRONT VIEW

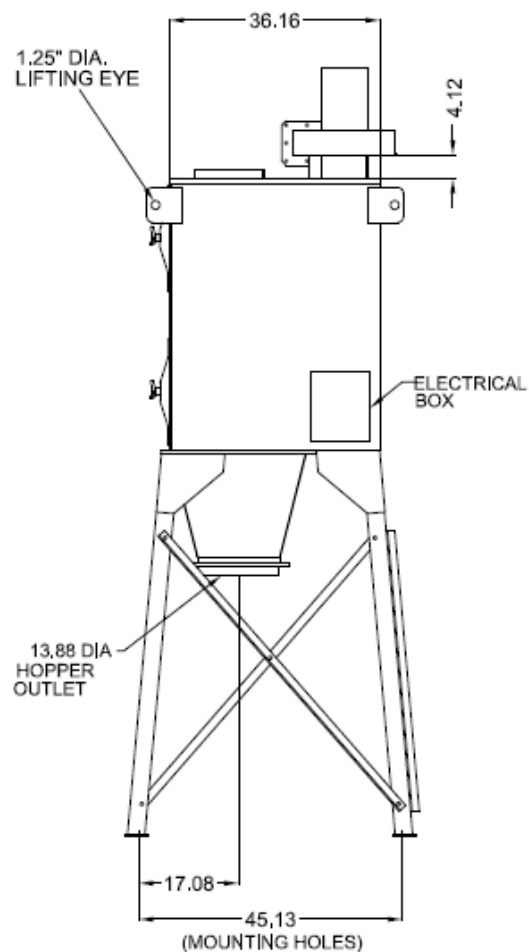

SIDE VIEW

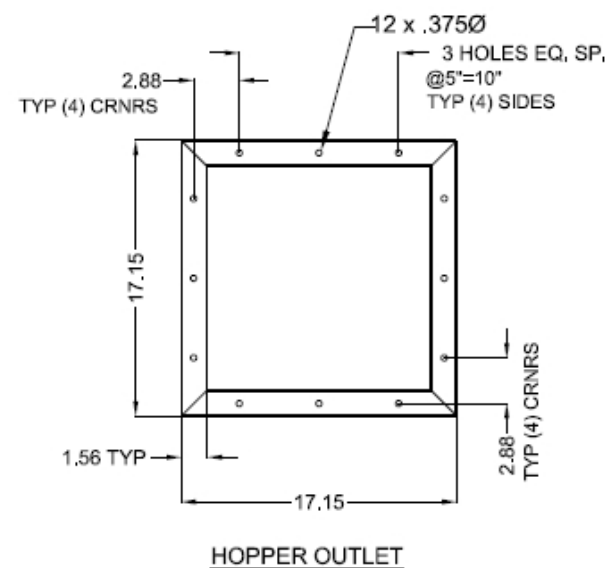
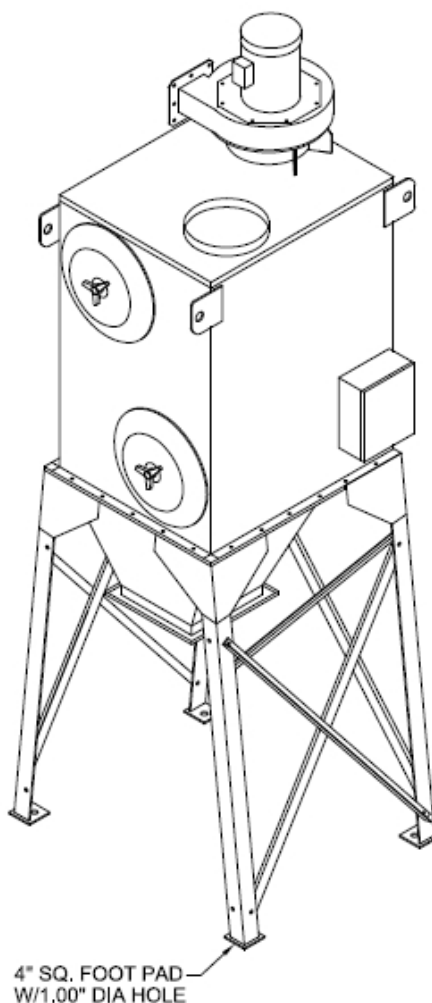

HOPPER OUTLET

SPECIFICATIONS:

MAIN FILTERS: (4) 16" Cartridge, CLEAN 2, std.
 (4) 16" Cartridge, Fiber Dust, opt.

HEPA OPTION: External HEPA filter, 99.97%

AD OPTION: (2) External adsorbers, 50 lbs., refillable, followed by a 2" poly afterfilter

OTHER OPTIONS: 55 Gallon lld/hose
 Slide gate
 50 Hz 5 Gal. container
 575 Volt 20 Gal. container
 Single phase
 Silencer
 Raincap

* AFS FILTER EFFICIENCIES BASED ON ASHRAE 52-76 TEST METHOD

CONSTRUCTION: 12 Gauge steel cabinet finished with a 2 part chemical and oil resistant paint. Includes removable endcaps for easy access to filters, pressure gauge to indicate filter changes, hopper with stand, and automatic cleaning. Also included is a direct drive radial motor/blower assembly. Motor starters/disconnects NOT INCLUDED.

WEIGHT: 583 lbs.

AIRFLOW: See chart below.

NOISE: See chart "A"

ELECTRICAL: 3 HP 208-230/460/3/60, 8.0/4.0 amps, radial blower, std.
 5 HP 208-230/460/3/60, 12.0/6.0 amps, radial blower, opt.

FIRE SUPPRESSION EQUIPMENT: Provided by others.

SPECIAL NOTES: Compressed air filter provided by others.

CHART A

MOTOR/BLOWER OPTIONS	MTR/BLWR HEIGHT	dBA	dBA WITH SILENCER
3 HP, RADIAL	15.00"	90	78
5 HP, RADIAL	19.50"	95	80

CHART B

STAND FOR:	A	B
55 GAL.	66	112.60
5/20 GAL.	42	88.60

MOTOR/BLOWER OPTION	"wg EXTERNAL ADDED STATIC								
	1	2	3	4	5	6	7	8	9
3 HP, RADIAL	1650	1600	1520	1420	1350	1170	900	600	—
5 HP, RADIAL	1950	1900	1800	1700	1575	1450	1300	1125	925

CUBIC FEET PER MINUTE (CFM)

04-02

CUSTOMER:
 CUSTOMER P.O.:
 PROJECT:
 ENGINEER:
 SALES REP.:
 IDENTIFICATION / TAGGING:

> www.lev-co.com • 1.888.862.5356

lev-co

The device depicted and described hereon embodies proprietary information owned by the manufacturer. All design, manufacturing, reproduction, sales and patent rights regarding this device or drawing reserved except where explicit right is guaranteed in writing. We reserve the right to make design changes.

Drawn by: Janos B
 Date: 5/1/2008
 Scale: NTS
 Weight: N/A

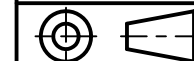

04-02 DC-4
CARTRIDGES DUST COLLECTOR
 Specification Drawing

Drawing No.: - File Name: (04-02) DC-4 - SD
 Material: Product manufactured by: Sheet: 1/2



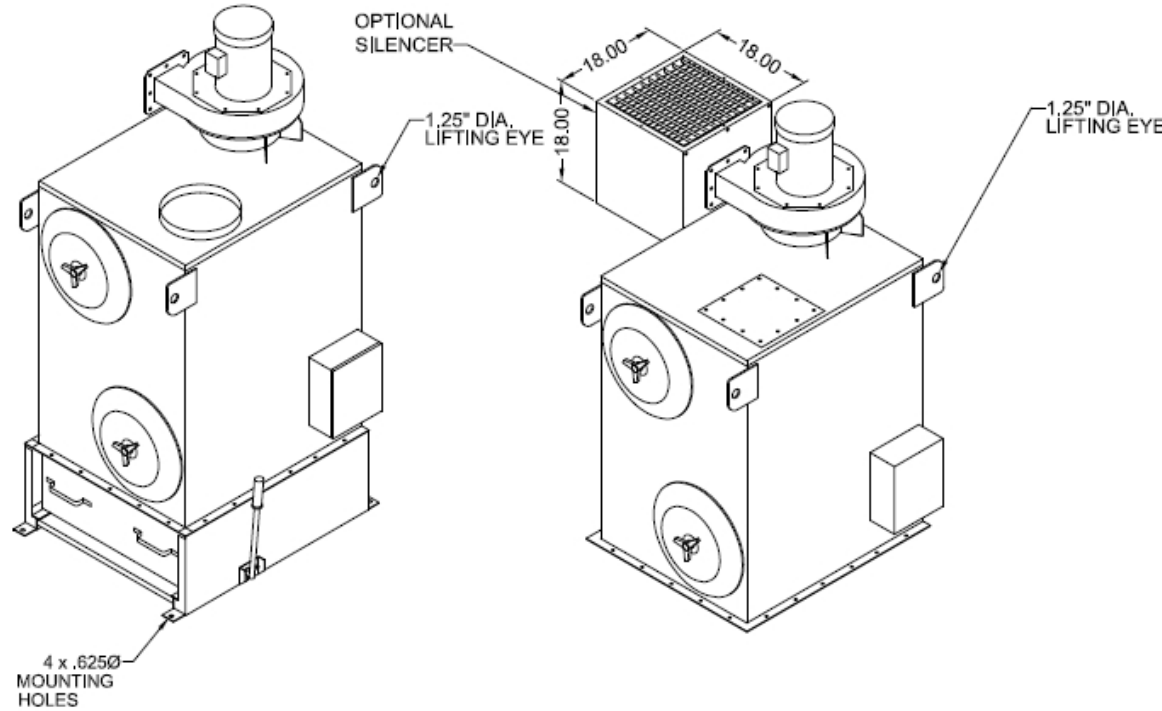
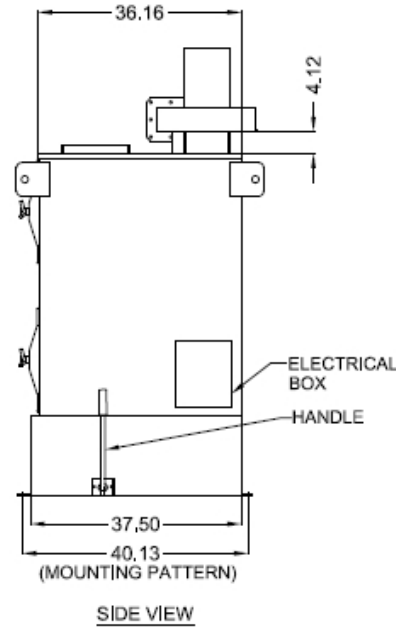
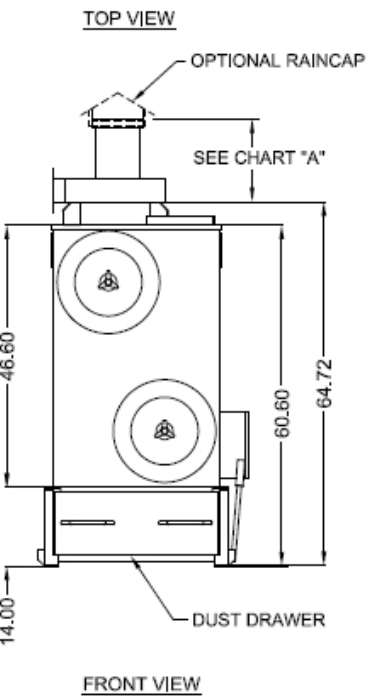
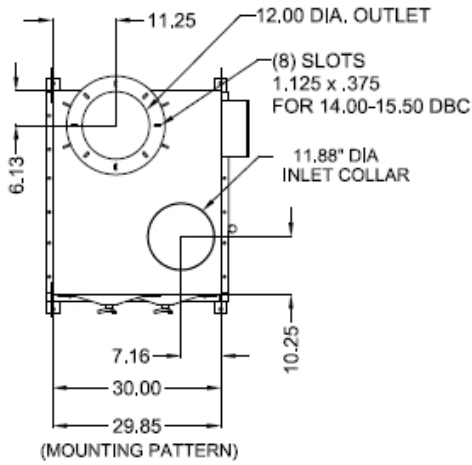

CONSTRUCTION: 12 Gauge steel cabinet finished with a 2 part chemical and oil resistant paint. Includes removable endcaps for easy access to filters, dust drawer, 6" legs, pressure gauge to indicate filter changes, and automatic cleaning. Also included is a direct drive radial motor/blower assembly. Motor starters/disconnects NOT INCLUDED.

WEIGHT: 573 lbs.

AIRFLOW: See Chart Below

NOISE: See Chart "A"

ELECTRICAL: 3 HP 208-230/460/3/60, 8.0/4.0 amps, radial blower, std.
 5 HP 208-230/460/3/60, 12.0/6.0 amps, radial blower, opt.

FIRE SUPPRESSION EQUIPMENT: Provided by others.

SPECIAL NOTES: Compressed air filter provided by others.

SPECIFICATIONS:

MAIN FILTERS: (4) 16" Cartridge, CLEAN 2, std.
 (4) 16" Cartridge, Fiber Dust, opt.

HEPA OPTION: External HEPA filter, 99.97%

AD OPTION: (2) External adsorbers, 50 lbs., refillable, followed by a 2" poly afterfilter

OTHER OPTIONS: Casters
 50 Hz
 575 Volt
 Single phase
 Silencer
 Raincap

* AFS FILTER EFFICIENCIES BASED ON ASHRAE 52-76 TEST METHOD

MODELS & OPTIONS:

Part # Description

Main System / Part

DC-4 Cartridge dust collector w/(4) Clean-2® cartridge filters (150ft² of media each), AUTO-CLEAN VIBRA-PULSE® filter cleaning system, top mounted 3 HP TEFC motor 208-230/460/575/3/60Hz (8/4) amps, with AMCA Type B, non-sparking, aluminum, radial blower wheel, 1/2" NPT regulator and motor wired to electrical control box, 12" dia. inlet collar on top, with a removable 4.25ft² external dust tray. (Motor starters not included.)

DC-4-H55 Cartridge dust collector w/ (4) Clean-2® cartridge filters (150ft² of media each), AUTO-CLEAN VIBRA-PULSE® filter cleaning system, top mounted 3 HP TEFC motor 208-230/460/575/3/60Hz (8/4) amps, AMCA Type B, non-sparking, aluminum radial blower wheel, 1/2" NPT regulator, and motor wired to electrical control box, 12" dia. inlet collar on top, hopper with legs, connecting hose, and lid for 55 gallon drum (motor starters and drums NOT included).

Fan / Motor Upgrades or Options (when ordering main unit)

- DC-4-5HP-BI 5HP BI Blower Option for Standard DC-4 Unit
- DC-4-5HP-R 5HP Radial Motor Option for Standard DC-4 Unit
- DC-4-7.5HP-BI 7.5 HP backward incline blower in place of 5 HP radial. (Add 53lbs. to ship weight.)
- DC-4-BIN VENT Filter Unit w/3HP Blower (less dust tray) Option for Standard DC-4 Unit
- DC-4-DEL Delete 3HP Blower from Standard Units-(add nothing) Option for Standard DC-4 Unit

Filter Options (when ordering main unit)

- DC-4-EXT-AD2 External AD-2000 CFM (Includes Silencer) Option for Standard DC-4 Unit
- DC-4-EXT-AD4 External AD-4000 CFM (Includes Silencer) Option for Standard DC-4 Unit
- DC-4-EXT-HE2 External Hepa-2000 CFM (Includes Silencer) Option for Standard DC-4 Unit
- DC-4-EXT-HE4 External Hepa-4000 CFM (Includes Silencer) Option for Standard DC-4 Unit
- DC-4-FD FiberDust Cartridge Filter Option for Standard DC-4 Unit
- DC-4-HYD-045 Hydro-filter designed to help eliminate sparks. C/w 45 gallon drum, easy to remove lid, water level gauge, and all required ductwork

Preventative Maintenance Pressure Gauges, etc. (when ordering main unit)

- DC-4-PG-10 0-10" magna-helic pressure gauge, approximately 5" diameter size. Surface mounted.

Misc. Options

- DC-4-HOPPER-20 20 Gal. Hopper Option for Standard DC-4 Unit
- DC-4-HOPPER-5 5 Gal. Hopper Option for Standard DC-4 Unit
- DC-4-M/C-4 Manual Vibra Clean System Option for Standard DC-4 Unit
- DC-4-CHK DAMPER Inlet Check Damper Option for Standard DC-4 Unit
- DC-4-EXP VENT Explosion Vent Door Option for Standard DC-4 Unit
- DRUM-45 45 imperial gallon (55 US gallons) steel drum c/w lid.

Sound Attenuation

- DC-4-S-BI 5 & 7.5HP BI Blower Silencer Option for Standard DC-4 Unit
- DC-4-S-RAD 3 & 5HP Radial Silencer Option for Standard DC-4 Unit

Installation Option & Accessories

- DC-4-GATE Slide Gate Option for Standard DC-4 Unit
- DC-4-RS Rain Shield Kit Option for Standard DC-4 Unit

04-02

CUSTOMER:
CUSTOMER P.O.:
PROJECT:
ENGINEER:
SALES REP.:
IDENTIFICATION / TAGGING:

> www.lev-co.com • 1.888.862.5356

lev-co

The device depicted and described hereon embodies proprietary information owned by the manufacturer. All design, manufacturing, reproduction, sales and patent rights regarding this device or drawing reserved except where explicit right is guaranteed in writing. We reserve the right to make design changes.

Drawn by:	Janos B
Date:	5/1/2008
Scale:	NTS
Weight:	N/A

04-02 DC-4	
CARTRIDGES DUST COLLECTOR	
Specification Drawing	
Drawing No.:	-
File Name:	(04-02) DC-4 - SD
Material:	Product manufactured by:
Sheet:	2/2