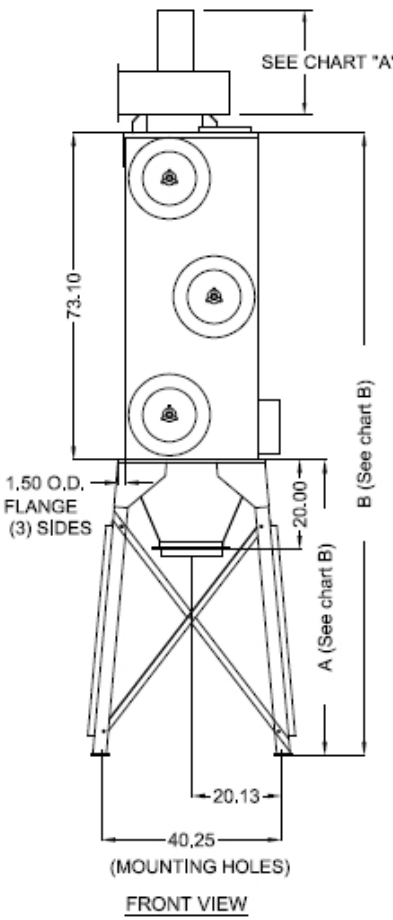

CHART B

STAND FOR:	A	B
55 GAL.	66	139.10
5/20 GAL.	42	115.10

TOP VIEW



FRONT VIEW

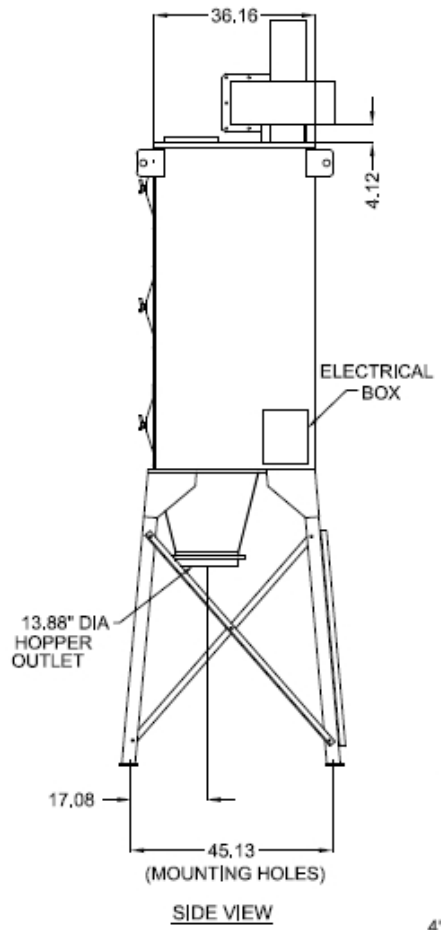

SIDE VIEW

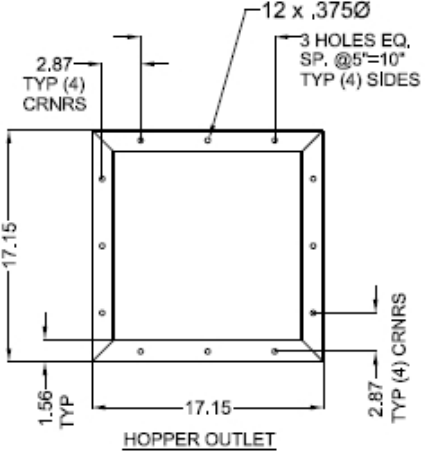
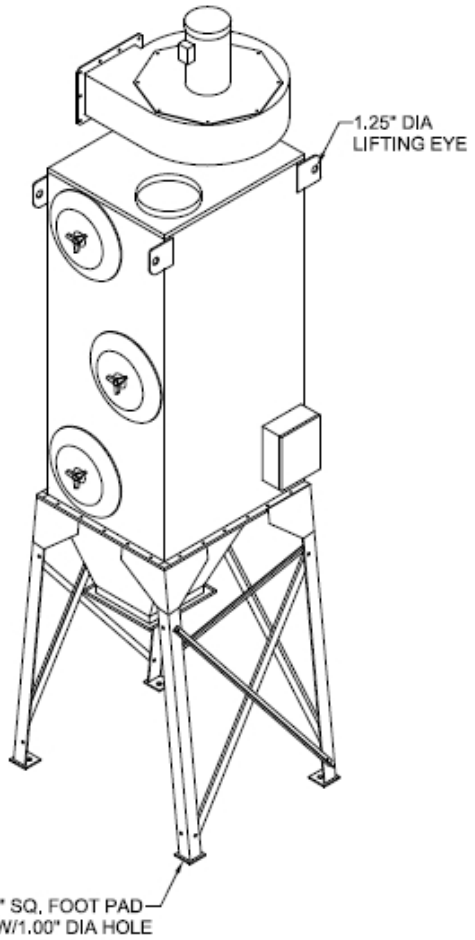

HOPPER OUTLET

MOTOR/BLOWER OPTION	"wg EXTERNAL ADDED STATIC								
	1	2	3	4	5	6	7	8	9
3 HP, RADIAL	1650	1600	1550	1450	1370	1180	910	605	—
5 HP, RADIAL	2000	1950	1875	1750	1600	1450	1300	1125	925
5 HP, BI	3450	3250	3000	2650	2250	1700	—	—	—
7.5 HP, BI	4300	4100	3950	3650	3300	2900	—	—	—

CUBIC FEET PER MINUTE (CFM)

SPECIFICATIONS:

- MAIN FILTERS:** (6) 16" Cartridge, CLEAN 2, std.
 (6) 16" Cartridge, Fiber Dust, opt.
- HEPA OPTION:** External HEPA filter, 99.97% (2000 CFM)
 External HEPA filter, 99.97% (4000 CFM)
- AD OPTION:** (2) External adsorbers, 50 lbs., refillable, followed by a 2" poly afterfilter (2000 CFM)
 (2) External adsorbers, 50 lbs., refillable, followed by a 2" poly afterfilter (4000 CFM)
- OTHER OPTIONS:** 55 Gallon lld/hose
 Slide gate
 50 Hz
 575 Volt
 Single phase
 Silencer
 Raincap
 5 Gal. container
 20 Gal. container
- * AFS FILTER EFFICIENCIES BASED ON ASHRAE 52-76 TEST METHOD

CONSTRUCTION: 12 Gauge steel cabinet finished with a 2 part chemical and oil resistant paint. Includes hopper and stand, removable endcaps for easy access to filters, pressure gauge to indicate filter changes, and automatic cleaning. Also included is a direct drive radial motor/blower assembly. Motor starters/dlconnects NOT INCLUDED.

WEIGHT: 783 lbs.

AIRFLOW: See chart below

NOISE: See chart "A"

ELECTRICAL: 3 HP 208-230/460/3/60, 8.0/4.0 amps, radial blower, std.
 5 HP 208-230/460/3/60, 12.0/6.0 amps, radial blower, opt.
 5 HP 208-230/460/3/60, 12.0/6.0 amps, BI blower, opt.
 7.5 HP 208-230/460/3/60, 17.2/8.6 amps, BI blower, opt.

FIRE SUPPRESSION EQUIPMENT: Provided by others.

SPECIAL NOTES: Compressed air filter provided by others.

OPTIONAL SILENCERS

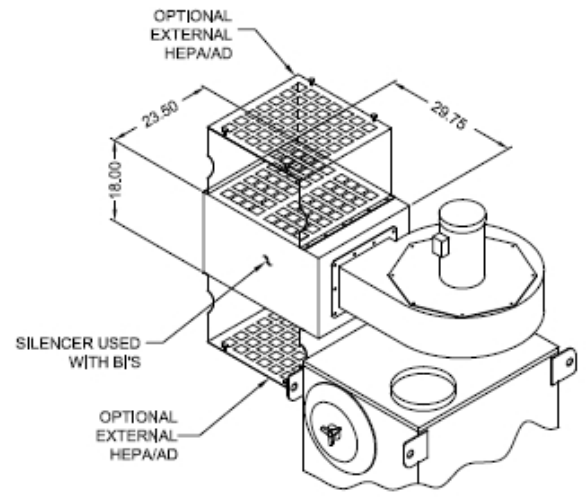

SILENCER USED WITH BIFS

OPTIONAL EXTERNAL HEPA/AD

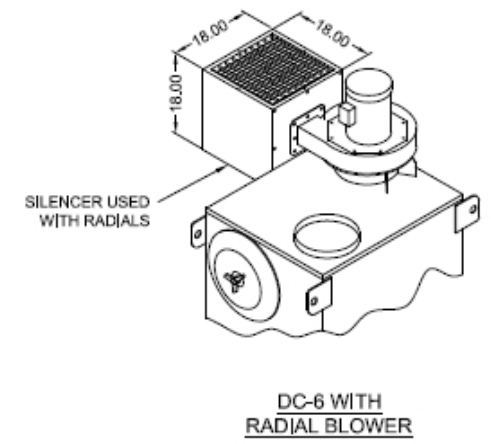

SILENCER USED WITH RADIALS

DC-6 WITH RADIAL BLOWER

04-03

CUSTOMER:
CUSTOMER P.O.:
PROJECT:
ENGINEER:
SALES REP.:
IDENTIFICATION / TAGGING:

> www.lev-co.com • 1.888.862.5356



The device depicted and described hereon embodies proprietary information owned by the manufacturer. All design, manufacturing, reproduction, sales and patent rights regarding this device or drawing reserved except where explicit right is guaranteed in writing. We reserve the right to make design changes.

Drawn by:	Janos B
Date:	5/1/2008
Scale:	NTS
Weight:	N/A

04-03 DC-6	
CARTRIDGES DUST COLLECTOR	
Specification Drawing	
Drawing No.:	File Name: (04-03) DC-6 - SD
Material:	Product manufactured by:
Sheet: 1/2	

MODELS & OPTIONS: ==>

SPECIFICATIONS:

CONSTRUCTION: 12 Gauge steel cabinet finished with a 2 part chemical and oil resistant paint. Includes removable endcaps for easy access to filters, dust drawer, 6" legs, pressure gauge to indicate filter changes, and automatic cleaning. Also included is a direct drive radial motor/blower assembly. Motor starters/disconnects NOT INCLUDED.

WEIGHT: 743 lbs.

AIRFLOW: See Chart Below

NOISE: See chart "A"

ELECTRICAL: 3 HP 208-230/460/3/60, 8.0/4.0 amps, radial blower, std.
 5 HP 208-230/460/3/60, 12.0/6.0 amps, radial blower, opt.
 5 HP 208-230/460/3/60, 12.0/6.0 amps, BI blower, opt.

FIRE SUPPRESSION EQUIPMENT: Provided by others.

SPECIAL NOTES: Compressed air filter provided by others.

MAIN FILTERS: (6) 16" Cartridge, CLEAN 2, std.
 (6) 16" Cartridge, Fiber Dust, opt.

HEPA OPTION: External HEPA filter, 99.97%

AD OPTION: (2) External adsorbers, 50 lbs., refillable, followed by a 2" poly afterfilter

OTHER OPTIONS: Casters
 50 Hz
 575 Volt
 Single phase
 Silencer
 Raincap

* AFS FILTER EFFICIENCIES BASED ON ASHRAE 52-76 TEST METHOD

CHART A

MOTOR/BLOWER OPTIONS	MTR/BLWR HEIGHT	dBA	dBA WITH SILENCER
3 HP, RADIAL	15.00"	90	78
5 HP, RADIAL	19.50"	95	80
5 HP, BI	23.38"	84	75

MOTOR/BLOWER OPTION	"wg EXTERNAL ADDED STATIC								
	1	2	3	4	5	6	7	8	9
3 HP, RADIAL	1650	1600	1550	1450	1370	1180	910	605	—
5 HP, RADIAL	2000	1950	1875	1750	1600	1450	1300	1125	925
5 HP, BI	3450	3250	3000	2650	2250	1700	—	—	—

CUBIC FEET PER MINUTE (CFM)

Part # Description

Main System / Part

- DC-6 Cartridge dust collector w/(6) Clean 2® filters, front load, 3 HP motor/blower with AMCA Type B spark resistant aluminum blower wheel, 4.25 ft³, 11" deep removable dust pan, & auto-clean Vibra-Pulse® cleaning system with ½" regulator.
- DC-6-H55 Cartridge dust collector w/55 gal. hopper, (6) Clean 2® filters, front load, 3 HP motor/blower with AMCA Type B spark resist. aluminum blower wheel, 4.25 ft³, 11" deep removable dust pan, & auto-clean Vibra-Pulse® with ½" regulator.

Fan / Motor Upgrades or Options (when ordering main unit)

- DC-6-5HP-BI 5HP BI Blower Option for Standard DC-6 Unit
- DC-6-5HP-R 5HP Radial Motor Option for Standard DC-6 Unit
- DC-6-7.5HP-BI 7.5HP BI Blower Option for Standard DC-6 Unit
- DC-6-BIN VENT Filter Unit w/3HP Blower (less dust tray) Option for Standard DC-6 Unit
- DC-6-DEL Delete 3HP Blower from Standard Units (add nothing) Option for Standard DC-6 Unit

Filter Options (when ordering main unit)

- DC-6-EXT-AD2 External AD-2000 CFM (Includes Silencer) Option for Standard DC-6 Unit
- DC-6-EXT-AD4 External AD-4000 CFM (Includes Silencer) Option for Standard DC-6 Unit
- DC-6-EXT-HE2 External Hepa-2000 CFM (Includes Silencer) Option for Standard DC-6 Unit
- DC-6-EXT-HE4 External Hepa-4000 CFM (Includes Silencer) Option for Standard DC-6 Unit
- DC-6-FD FiberDust Cartridge Filter Option for Standard DC-6 Unit
- DC-6-HYD-045 Hydro-filter designed to help eliminate sparks. C/w 45 gallon drum, easy to remove lid, water level gauge, and all required ductwork

Preventative Maintenance Pressure Gauges, etc. (when ordering main unit)

- DC-6-PG-10 0-10" magna-helic pressure gauge, approximately 5" diameter size. Surf:cc mounted.

Misc. Options

- DC-6-HOPPER Hopper/stand option (no dust pans) - 3 HP blower, available with all other options. Capacity: 4.25 cu ft. Includes legs and lid for 55 gal. drum (Add 2 to ship weight.)
- DC-6-HOPPER-20 20 Gal. Hopper Option for Standard DC-6 Unit
- DC-6-HOPPER-5 5 Gal. Hopper Option for Standard DC-6 Unit
- DC-6-M/C-6 Manual Vibra Clean System Option for Standard DC-6 Unit
- DC-6-VENT Explosion vent door, 2.25 ft.2. (Add 20 lbs to ship weight.)
- DC-6-BLOCK OFF Block Off Components Option for Standard DC-6 Unit
- DC-6-CHK DAMPER Inlet Check Damper Option for Standard DC-6 Unit
- DC-6-EXP VENT Explosion Vent Door Option for Standard DC-6 Unit
- DRUM-45 45 imperial gallon (55 US gallons) steel drum c/w lid.

Sound Attenuation

- DC-6-SR Silencer 3HP, 5HP radial blowers.
- DC-6-SR-BI Silencer for 5 and 7.5 BI blowers.
- DC-6-S-BI 5 & 7.5HP BI Blower Silencer Option for Standard DC-6 Unit
- DC-6-S-RAD 3 & 5HP Radial Silencer Option for Standard DC-6 Unit

Installation Option & Accessories

- DC-6-GATE Slide Gate Option for Standard DC-6 Unit
- DC-6-RS Rain Shield Kit Option for Standard DC-6 Unit

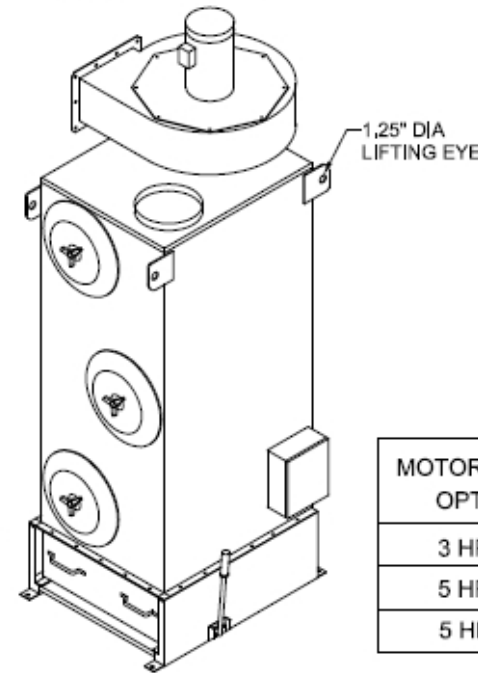
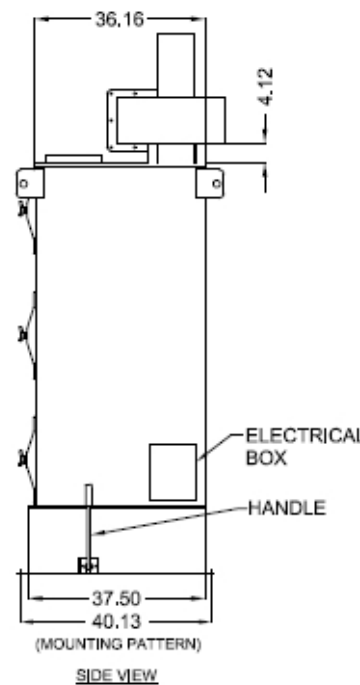
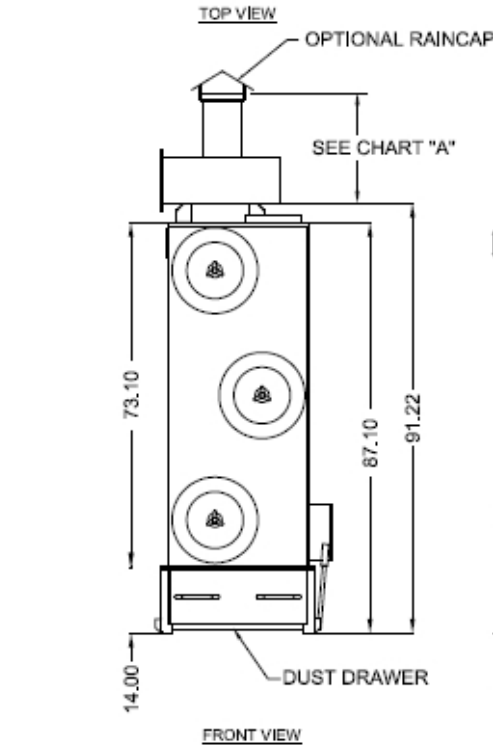
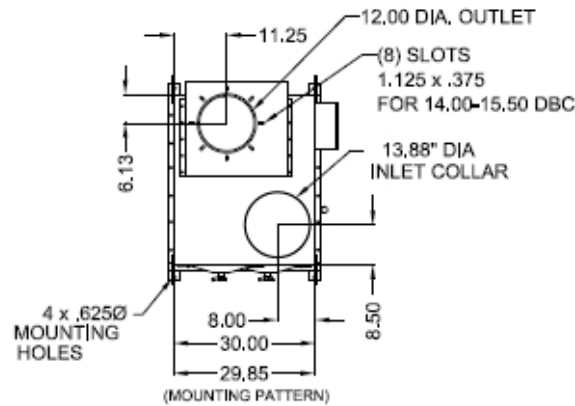

CUSTOMER:
 CUSTOMER P.O.:
 PROJECT:
 ENGINEER:
 SALES REP.:
 IDENTIFICATION / TAGGING:

www.lev-co.com • 1.888.862.5356



The device depicted and described hereon embodies proprietary information owned by the manufacturer. All design, manufacturing, reproduction, sales and patent rights regarding this device or drawing reserved except where explicit right is guaranteed in writing. We reserve the right to make design changes.

Drawn by: Janos B
 Date: 5/1/2008
 Scale: NTS
 Weight: N/A

04-03 DC-6

CARTRIDGES DUST COLLECTOR

Specification Drawing

Drawing No.: - File Name: (04-03) DC-6 - SD
 Material: Product manufactured by: **Airflow SYSTEMS INC.** Sheet: 2/2