

TOP VIEW

AIR OUTLET

CONSTRUCTION: 18 Gauge welded steel cabinet finished with 2 part chemical and oil resistant finish. Includes removable, hinged acrylic sides and top shield, built-in side handles, 6' power cord, on-off switch, and running light. Portable.

WEIGHT: 61 lbs.

AIRFLOW: 230 CFM
170 CFM (w/HEPA or V-BANK)

NOISE LEVEL: 54 dBA-HI, 51 dBA-LO, @5'

ELECTRICAL: 1/10 HP 115 V, 2.7 amps, 1 speed, std.
 1/10 HP 115 V, 1.8 amps, 1 speed, opt.

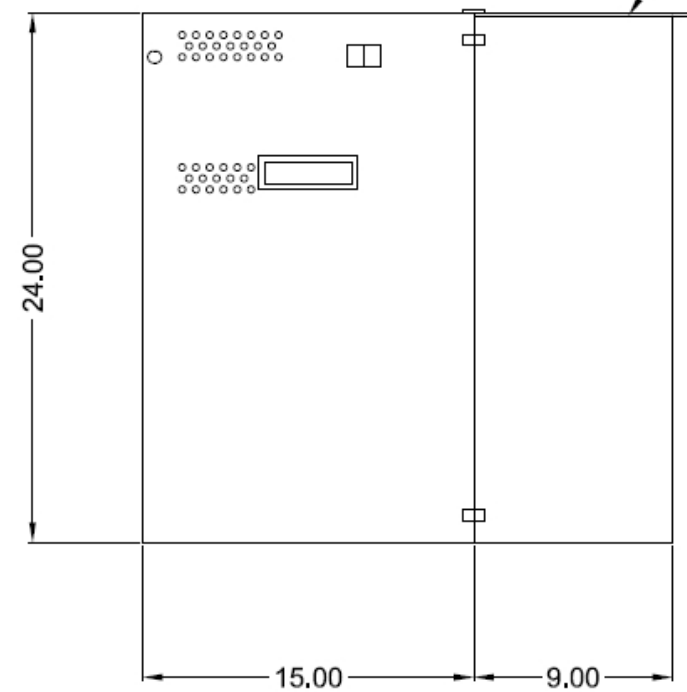

SIDE VIEW

CLEAR TOP & SIDE SHIELDS

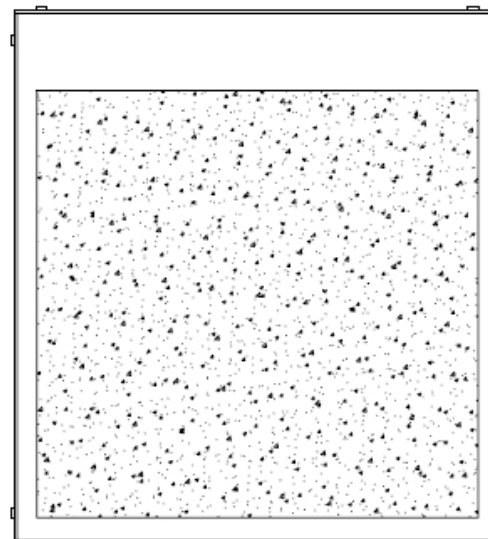

FRONT VIEW

SPECIFICATIONS:

PREFILTERS: (1) 1" polyester, std.

MAIN FILTERS: (1) 14 ft² 98%, std.
 (1) 99.97% D.O.P. HEPA, opt.

AFTER FILTERS: (1) 2" charcoal, std.

AD OPTION: (1) refillable v-bank adsorber module, 7 lb. capacity, in place of 98% filter, opt.

OTHER OPTIONS: Extended side shield, extends width to 30".

* AFS FILTER EFFICIENCIES BASED ON ASHRAE 52-76 TEST METHOD

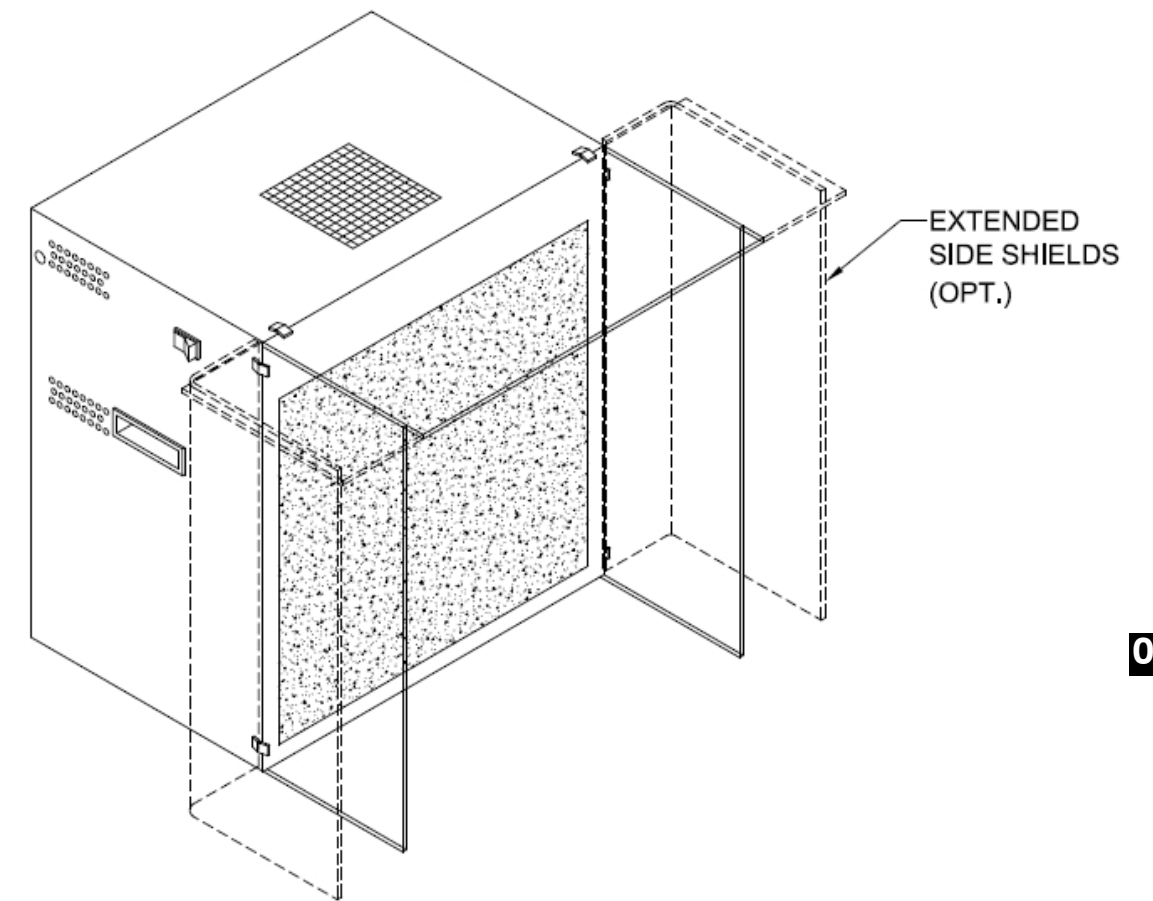

EXTENDED SIDE SHIELDS (OPT.)

08-01

CUSTOMER:
CUSTOMER P.O.:
PROJECT:
ENGINEER:
SALES REP.:
IDENTIFICATION / TAGGING:

> www.lev-co.com • 1.888.862.5356

lev-co

The device depicted and described hereon embodies proprietary information owned by the manufacturer. All design, manufacturing, reproduction, sales and patent rights regarding this device or drawing reserved except where explicit right is guaranteed in writing. We reserve the right to make design changes.

Drawn by:	JANOS-B
Date:	5/1/2008
Scale:	NTS
Weight:	N/A

08-01 Fume Booth

Specification Drawing

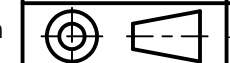

Drawing No.:	-	File Name:	(08-01) Fume Booth - SD
Material:	-	Product manufactured by:	Airflow SYSTEMS INC.
			Sheet: 1/2

MODELS & OPTIONS

Part # **Description**

Main System / Part

_____ Fume/Booth Portable desk-top air cleaner with (1) 1" thick polyester prefilter (1) 65% pleated main filter (14 sq. ft. of media) (1) 2" thick disposable charcoal filter and an ODOR/EX deodorizer.

Filter Options (when ordering main unit)

- _____ FB-95% 95% Main Filter in place of 65% standard filter
- _____ FB-AD Adsorption option. Includes (1) refillable v-bank adsorption module (7 lbs. capacity) with (1) 2" pleated afterfilter in place of standard 65% filter and standard 2" charcoal filter. Order charcoal separately.
- _____ FB-HEPA 99.97% Hepa Filter in place of standard 65% filter.

Misc. Options

- _____ FB-ESS Extended acrylic side shields extends width to 30" (Add 10 lbs. to ship weight).
- _____ FB-V550 Outside Vent Kit. Includes blower outlet adapter with 12 1/2' of 6" diameter flex hose. Can retrofit in the field. (Add 20 lbs. to ship weight.)
- _____ F120 3800 CFM unit w/4" pleated 30% prefilter 65% bag filter, 120 sq. ft. 2 HP TEFC motor, 208-230/460/3/60 Hz. Wired for 208V unless otherwise specified.

08-01

CUSTOMER:
 CUSTOMER P.O.:
 PROJECT:
 ENGINEER:
 SALES REP.:
 IDENTIFICATION / TAGGING:



www.lev-co.com • 1.888.862.5356



The device depicted and described hereon embodies proprietary information owned by the manufacturer. All design, manufacturing, reproduction, sales and patent rights regarding this device or drawing reserved except where explicit right is guaranteed in writing. We reserve the right to make design changes.

Drawn by: JANOS-B
 Date: 5/1/2008
 Scale: NTS
 Weight: N/A

08-01 Fume Booth	
Specification Drawing	
Drawing No.: -	File Name: (08-01) Fume Booth - SD
Material: Product manufactured by:	Sheet: 2/2