

WIRING DIAGRAM

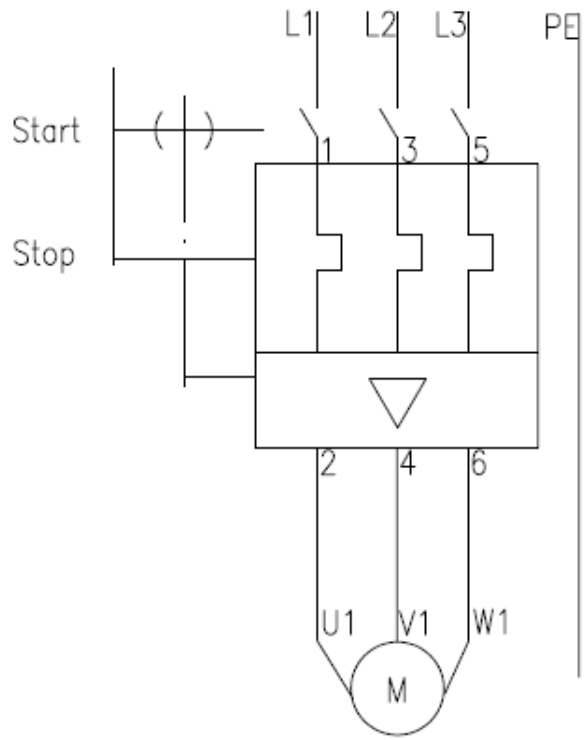

NOMEX	H [in]	A [in]	B [in]	D [in]
1000	71	30	25	6.3
2000	71	30	25	8
4000	79	45	41	12

11-09

CUSTOMER:
CUSTOMER P.O.:
PROJECT:
ENGINEER:
SALES REP.:
IDENTIFICATION / TAGGING:

> www.lev-co.com • 1.888.862.5356



The device depicted and described hereon embodies proprietary information owned by the manufacturer. All design, manufacturing, reproduction, sales and patent rights regarding this device or drawing reserved except where explicit right is guaranteed in writing. We reserve the right to make design changes.

Drawn by: JANOS B
Date: 5/1/2008
Scale: NTS
Weight: N/A

**11-09 NOMEX
Mist Collector**
Specification Drawing



Drawing No.: - File Name: (11-09) Nomex - SD
Material: - Sheet: 1/2

MODELS & OPTIONS

Part #

Description

Main System / Part

- ___ NX-600-1 **NOMEX® 600** mechanical oilmist filter 600 CFM c/w 1.5 HP 208-230V/460V/3/60 motor and one (1) washable filter box. An OPTIONAL HEPA afterfilter (99.99%) not washable available. Inlet 160mm (6.5") Ø.
- ___ NX-600-2 **NOMEX® 600** mechanical oilmist filter 600 CFM c/w 1.5 HP 575-600V/3/60 motor and one (1) washable filter box. An OPTIONAL HEPA afterfilter (99.99%) not washable available. Inlet 160mm (6.5") Ø.
- ___ NX-1200-2 **NOMEX® 1200** mechanical oilmist filter 1200 CFM c/w 3 HP 575-600V/3/60 motor and two (2) washable filter box. An OPTIONAL HEPA afterfilter (99.99%) not washable available. Inlet 200mm (8") Ø.
- ___ NX-2400-1 **NOMEX® 2400** mechanical oilmist filter 2400 CFM c/w 5 HP 208-230V/460V/3/60 motor and two (2) washable filters. An OPTIONAL HEPA afterfilter (99.99%) not washable available. Inlet 315mm (12") Ø.
- ___ NX-2400-2 **NOMEX® 2400** mechanical oilmist filter 2400 CFM c/w 5 HP 575-600V/3/60 motor and two (2) washable filters. An OPTIONAL HEPA afterfilter (99.99%) not washable available. Inlet 315mm (12") Ø.
- ___ NX-2000-1 **NOMEX® 2000** mechanical oilmist filter 2000 M3H c/w 3 HP 208-230V/460V/3/60 motor and two (2) washable filter box. An OPTIONAL HEPA afterfilter (99.99%) not washable available. Inlet 200mm (8") Ø.

Filter Options (when ordering main unit)

- ___ NX-600-HEPA HEPA Filter Option (99.99%) for **NOMEX® 600**. Not washable.
- ___ NX-1200-HEPA HEPA Filter Option (99.99%) for **NOMEX® 1200**. Not washable.
- ___ NX-2400-HEPA HEPA Filter Option (99.99%) for **NOMEX® 2400**. Not washable.

11-09

CUSTOMER:
CUSTOMER P.O.:
PROJECT:
ENGINEER:
SALES REP.:
IDENTIFICATION / TAGGING:

www.lev-co.com • 1.888.862.5356



The device depicted and described hereon embodies proprietary information owned by the manufacturer. All design, manufacturing, reproduction, sales and patent rights regarding this device or drawing reserved except where explicit right is guaranteed in writing. We reserve the right to make design changes.

Drawn by: JANOS B
Date: 5/1/2008
Scale: NTS
Weight: N/A

11-09 NOMEX Mist Collector	
Specification Drawing	
Drawing No.: -	File Name: (11-09) Nomex - SD
Material: -	Sheet: 2/2