

CONSTRUCTION: 12/14/16 Gauge steel cabinet finished with Powder-Coat Finish. Includes a 5 gallon external dust drawer, removable end cap for easy access to filter, removable panel for easy access to direct drive motor/blower, 25' 12 Ga. power cord, and on-off switch. Motor wired to junction box outside unit for 3 phase option. Acoustical lining standard in blower compartment. Vibra-Pulse cleaning standard. **10 ft Flexi-I Extractor arm - Standard**

WEIGHT: 200 lbs.
AIRFLOW: 600 CFM with std. 1 HP motor
 800 CFM with opt. 1.5 HP motor
NOISE: 71 dBA
ELECTRICAL: 1 HP 115 /1/60, 12 amps, std.
 1.5 HP 115/220/1/60, 15/7.9-7.5 amps, opt.
 1.5 HP 230/460/3/60, 4.9-4.6/2.3 amps, opt.

FIRE SUPPRESSION: Equipment provided by others.
SPECIAL NOTES: Compressed air filter provided by others.

SPECIFICATIONS:

MAIN FILTERS: (1) CLEAN-2 Filter cartridge, 16"Dx12", Std.
 (1) Cartridge, FIBERDUST , Opt.
 (1) Cartridge, Spark Resistant, Opt.
 (1) Cartridge, Spunbond - HO, Opt.
 (1) Cartridge, CleanPlus double treated fire retardant, Opt.

HEPA OPTIONS: (1) External HEPA filter, 99.97%

AD OPTION: (1) External adsorber, 25 lb. capacity

OTHER OPTIONS: Pressure gauge kit indicates filter changes
 Hopper option, 10 Gallon
 Auto Clean, (w/Hopper opt.)
 Regulator
 Silencer (Adds 3" to depth of unit)

* AFS FILTER EFFICIENCIES BASED ON ASHRAE 52-76 TEST METHOD

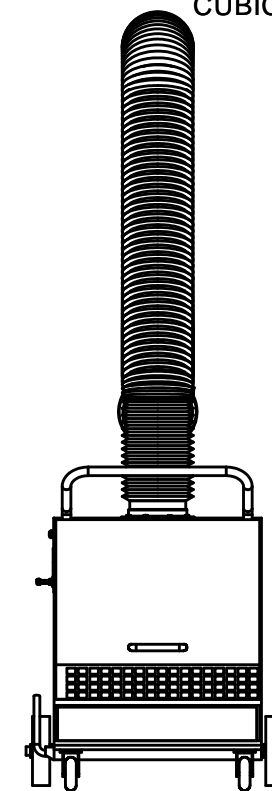
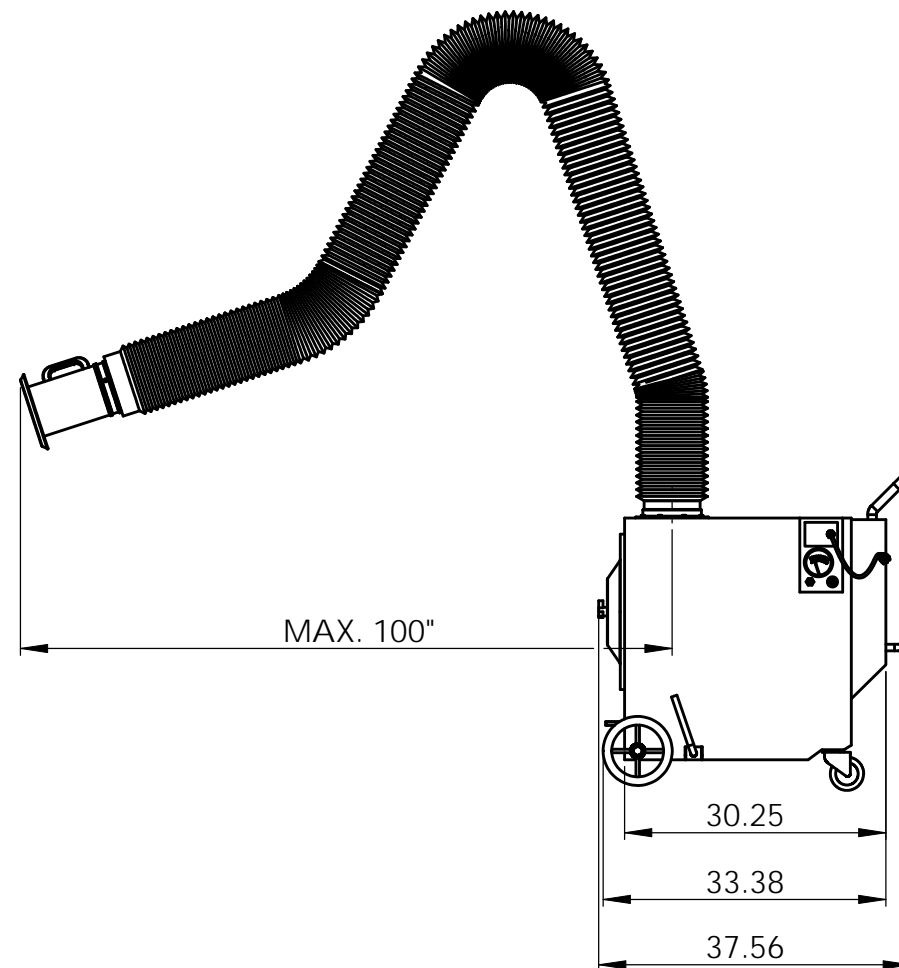
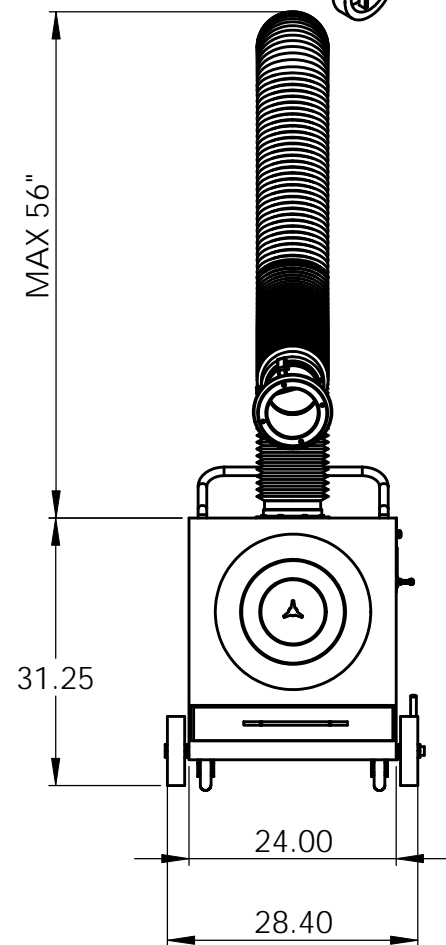
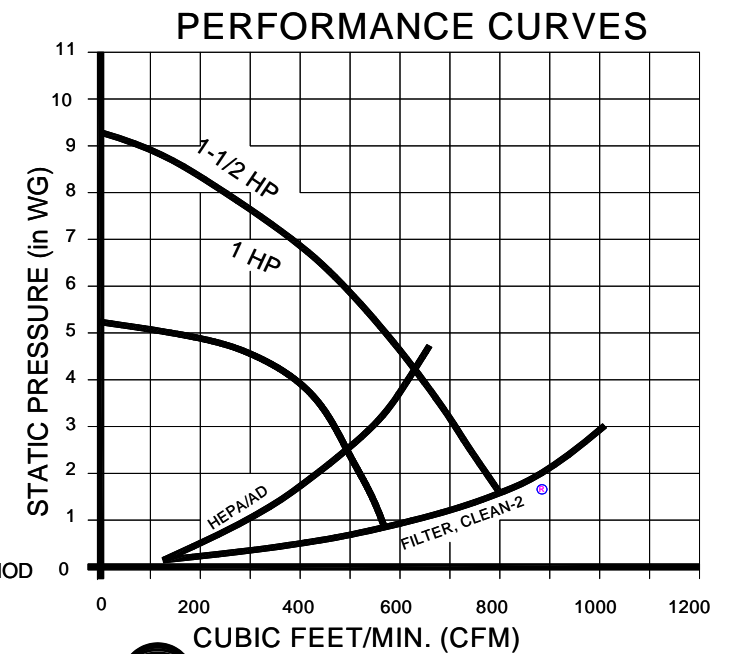

CUSTOMER:
 CUSTOMER P.O.:
 PROJECT:
 ENGINEER:
 SALES REP.:
 IDENTIFICATION / TAGGING:

> www.lev-co.com • 1.888.862.5356

lev-co

The device depicted and described hereon embodies proprietary information owned by the manufacturer. All design, manufacturing, reproduction, sales and patent rights regarding this device or drawing reserved except where explicit right is guaranteed in writing. We reserve the right to make design changes.

Drawn by: Janos B
 Date: 6/10/2008
 Scale: NTS
 Weight: N/A

MOBI-PULSE 1
Portable Dust Collector
 Specification Drawing

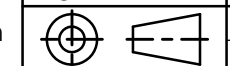

Drawing No.: -
 Material: -
 File Name: Mobi-Pulse 1 - SD
 Sheet: 1/2

MODELS & OPTIONS:

Main System / Part

- MPLS-1 Mobi-Pulse-1 Filtration unit c/w (1) only 10' Flexi-I Extraction arm (6" dia.) with damper, manual VIBRA-PULSE® filter cleaning system, a 1 HP 115/1/60 TEFC motor, backward incline blower, removable 5 gallon external dust drawer, 8" front wheels, and 5" rear swivel casters.

Fan / Motor Upgrades or Options (when ordering main unit)

- PCH-1-3 PHASE 1.5Hp, TEFC motor, 208-230/460/575/3/60 Hz Option for Standard PCH-1 Unit. Please note: This option does not add any addition airflow. If more flow is required, please see options # 6004 (PCH-1-HP-1) or # 6005 (PCH-1-HP-3)
- PCH-1-1PHASE-D 1.5 Hp, 1 phase, Class 1, Div. 2, Group D motor/blower for the PCH-1
- PCH-1-1/2HP Replace standard 1 HP motor with a 1/2HP, TEFC motor, 115/230/1/60, BI (600 CFM)

Hood Options

- P-019-020 Work Light 12 V Halogen 50 VA. for hood c/w 10m (33') cable with switch and step-down transformer 115V/12V.

Preventative Maintenance Pressure Gauges, etc. (when ordering main unit)

- MPLS1-PG-10 0-10" magna-helic pressure gauge, approximately 5" diameter size. Surface mounted.

Silencer Option (when ordering main unit)

- MPLS1-EXSIL External Silencer Option

Fan, Light & Other Electrical Accessories

- MPLS1- LIGHT Light kit c/w switch for light on the hood and safety mesh

Replacement filters - (Quantity discounts available upon request)

- 7FJ99003 99.97% @ 0.3 microns HEPA Filter for PCH/DCH/DTH/ALH units
- 7FR02020 Generic Flame Retardant Cartridge Filter made of 80/20% Cell/Poly Blend,. Replacement Filter for DCH/PCH/DTH series collectors (150 sq. ft. of media)

Replacement filters - (Quantity discounts available upon request)

- 7FR02020 - C2 Cartridge, CLEAN-2 ®, 150 sq.ft. of media

Replacement Parts

- 2BW12225 Impeller for P-153 and PCH-1/DCH-1/DTH-800 with 1.5 HP motor

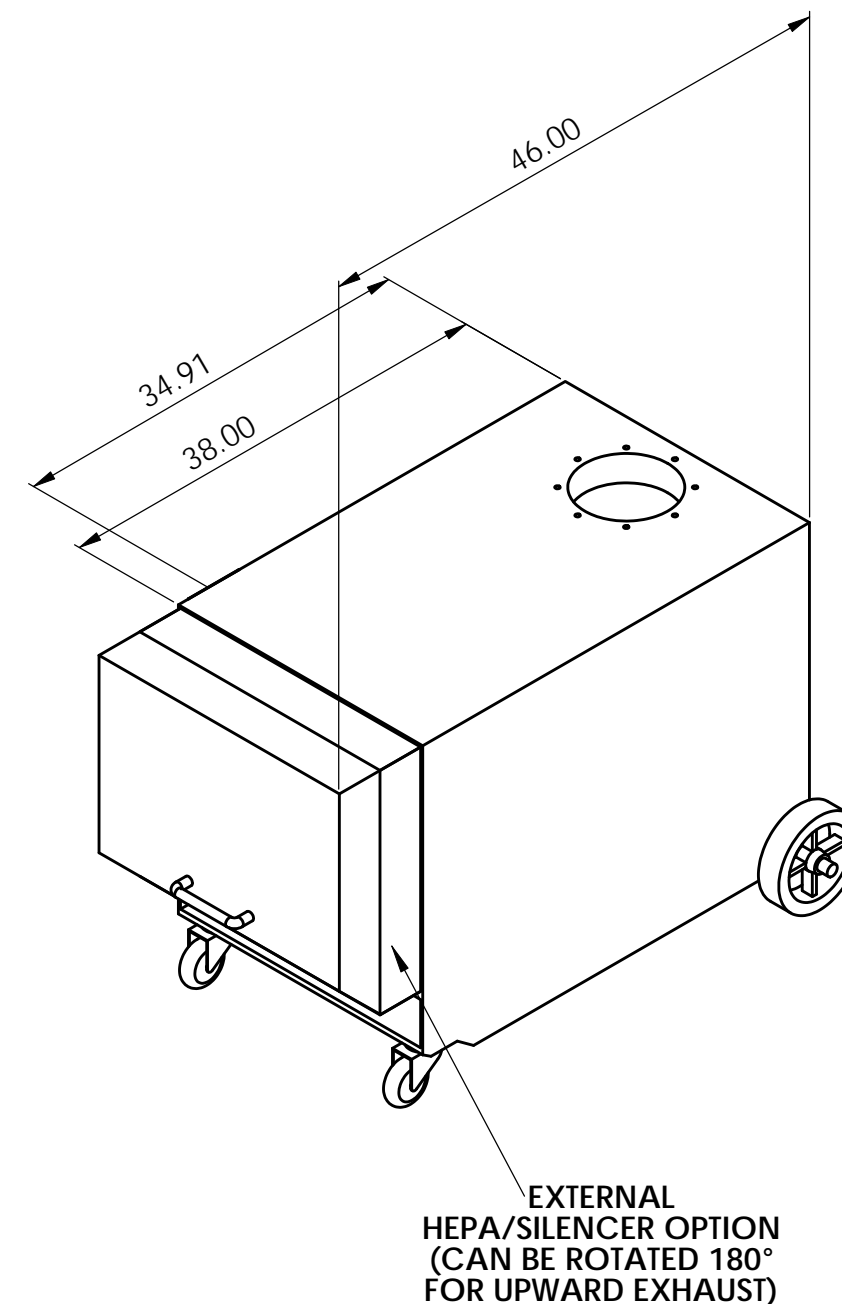

CUSTOMER:
CUSTOMER P.O.:
PROJECT:
ENGINEER:
SALES REP.:
IDENTIFICATION / TAGGING:

www.lev-co.com • 1.888.862.5356



The device depicted and described hereon embodies proprietary information owned by the manufacturer. All design, manufacturing, reproduction, sales and patent rights regarding this device or drawing reserved except where explicit right is guaranteed in writing. We reserve the right to make design changes.

Drawn by:	Janos B
Date:	6/10/2008
Scale:	NTS
Weight:	N/A

MOBI-PULSE 1	
Portable Dust Collector	
Specification Drawing	
Drawing No.:	-
Material:	-
File Name:	Mobi-Pulse 1 - SD
Sheet:	2/2