

CUSTOMER:
CUSTOMER PO:
PROJECT:
PROJECT NAME:
TAG:

H-MAX	A
H-MAX-FII-1	2m (7')
H-MAX-FII-2	3m (10')
H-MAX-FII-3	4m (14')
H-MAX-FII-1/D	2m (7')
H-MAX-FII-2/D	3m (10')
H-MAX-FII-3/D	4m (14')

Flexi-II Extractor Arm	B
P-143	2m (7')
P-144	3m (10')
P-145	4m (14')
P-146	5m (17')

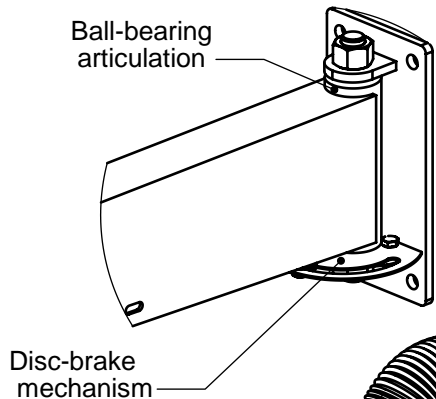

**Detail X**

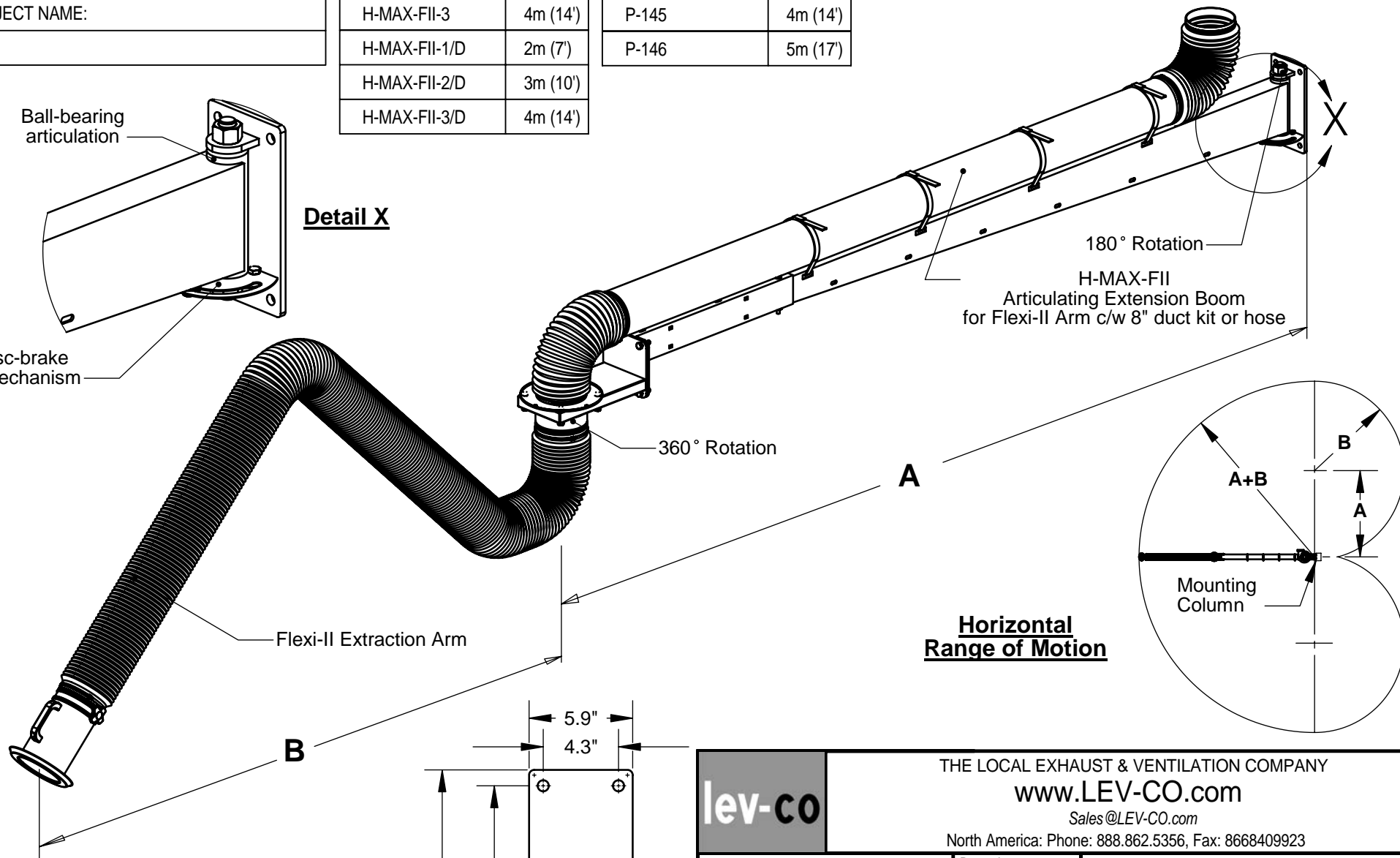

**Horizontal Range of Motion**

**Wall Mounting Flange**

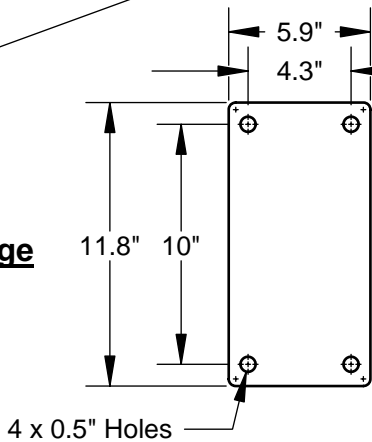

<b>lev-co</b>	THE LOCAL EXHAUST & VENTILATION COMPANY	
	www.LEV-CO.com	
	Sales@LEV-CO.com	
	North America: Phone: 888.862.5356, Fax: 8668409923	
The device depicted and described hereon embodies proprietary information owned by the manufacturer. All design, manufacturing, reproduction, sales and patent rights regarding this device or drawing reserved except where explicit right is guaranteed in writing. We reserve the right to make design changes.	Drawn by: Adrian Pop	Title: Flexi-II Extractor Arm w/ H-MAX Articulating Extension Boom Specification Drawing
	Date: 10/08/2005	
	Scale: NTS	
	Weight: 00.0	
	Drawing No.: S-20320-00	File Name:
	Material: -	Sheet: 1/1